

**FF-N20** OUTPUT(输出):APPROX(大概) 0.2~0.8W Precious metal-Brushmotors(金属电刷马达)

代表用途: 精密仪器  
家用电器

Typical Application/Precision Instruments  
Household Appliances

MODEL(型号)	VOLTAGE(电压)		NO LOAD(空载)		AT MAXIMUM EFFICIENCY (最大效率)				STALL(堵转)	
	RANGE (范围)	NOMINAL (额定)	SPEED (转速)	CURRENT (电流)	SPEED (转速)	CURRENT (电流)	TORQUE (转矩)	OUTPUT (输出)	TORQUE (转矩)	CURRENT (电流)
			r/min	A	r/min	A	gf.cm	w	g.cm	A
KFF-N20S-1948	1~3	1.5V CONSTANT	18000	0.12	12000	0.9	4	0.3	16	2.3
KFF-N20S-1090	1~6	6.0V CONSTANT	20000	0.10	14000	1.2	8	0.5	35	3.0

UNIT(单位):MILLIMETER(毫米)

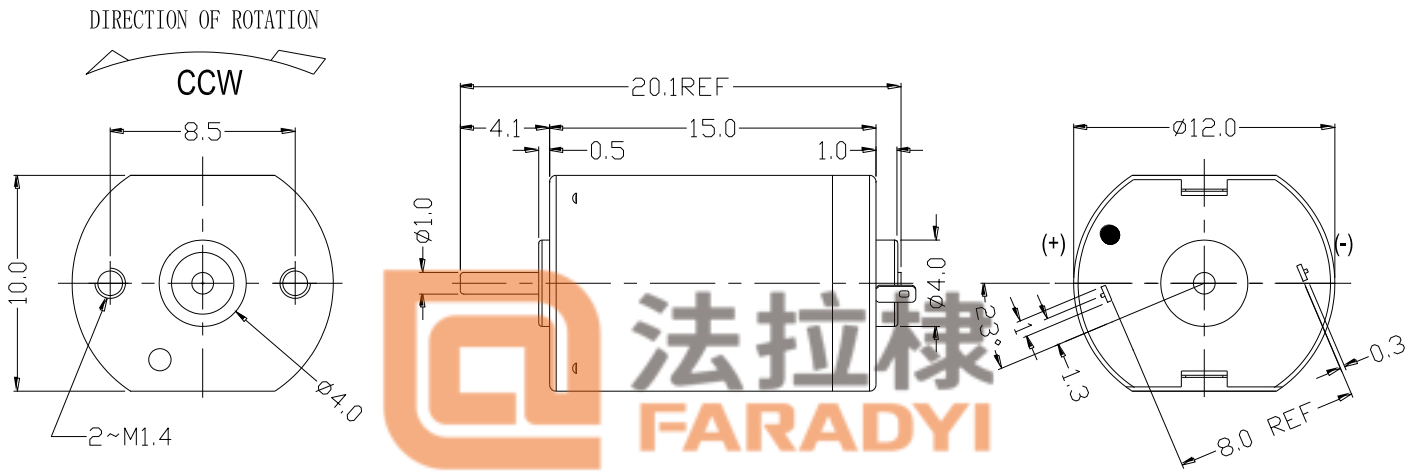

WEIGHT(重量):5.0g

电动机的特性曲线和特性参数:

型号: **KFF-N20S-1948**

电压: **1.5V**

(仅供参考)

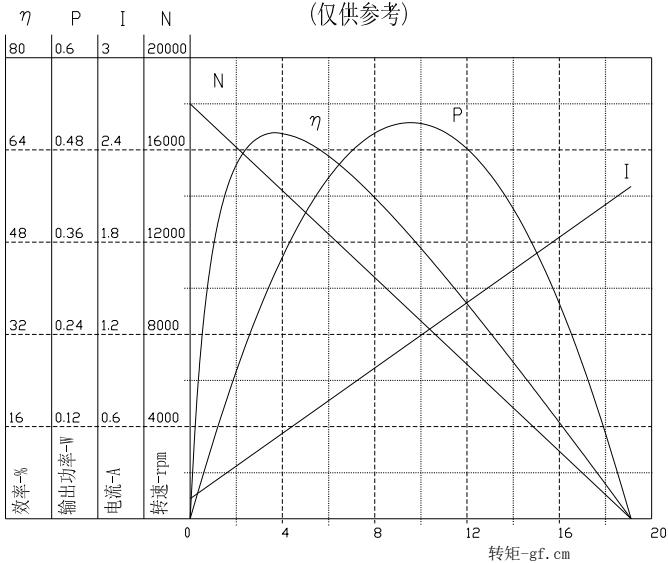

电动机的特性曲线和特性参数:

型号: **KFF-N20S-1090**

电压: **6.0V**

(仅供参考)

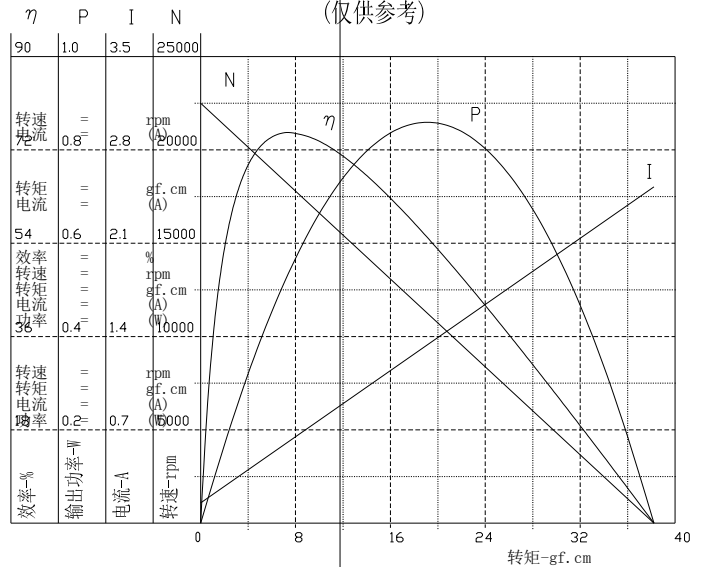

# FC-180SM OUTPUT(输出):APPROX(大概) 1.0~10W Carbon-Brushmotors(碳刷马达)

代表用途: 精密仪器  
家用电器

Typical Application/Precision Instruments  
Household Appliances

MODEL(型号)	VOLTAGE(电压)		NO LOAD(空载)		AT MAXIMUM EFFICIENCY (最大效率)				STALL(堵转)	
	RANGE (范围)	NOMINAL (额定)	SPEED (转速)	CURRENT (电流)	SPEED (转速)	CURRENT (电流)	TORQUE (转矩)	OUTPUT (输出)	TORQUE (转矩)	CURRENT (电流)
			r/min	A	r/min	A	gf.cm	w	g.cm	A
KFC-180SM-2852	1~3	2.4V CONSTANT	8400	0.16	6950	0.86	18	1.29	116	4.57
KFC-180SM-4022	1.0~1.5	1.2V CONSTANT	9500	0.39	8000	1.80	15	1.25	108	9.50
KFC-180SM-10320	6~12	12V CONSTANT	6500	0.03	5300	0.12	7.5	0.42	85	0.55



UNIT(单位):MILLIMETER(毫米)

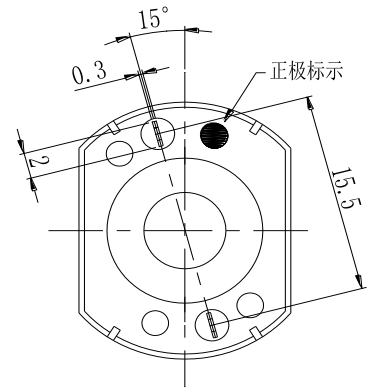
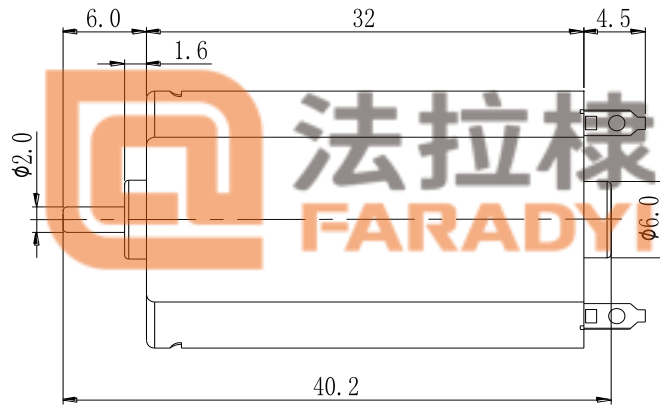
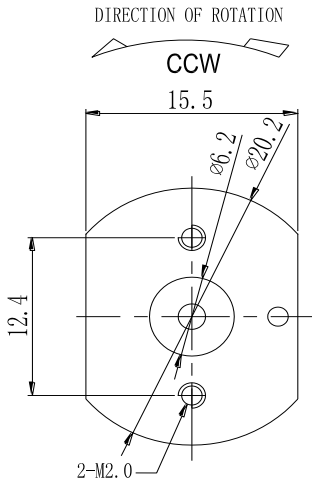

WEIGHT(重量):32g

电动机的特性曲线和特性参数:

型号: **KFC-180SM-2852**

电压: **2.4V**

(仅供参考)

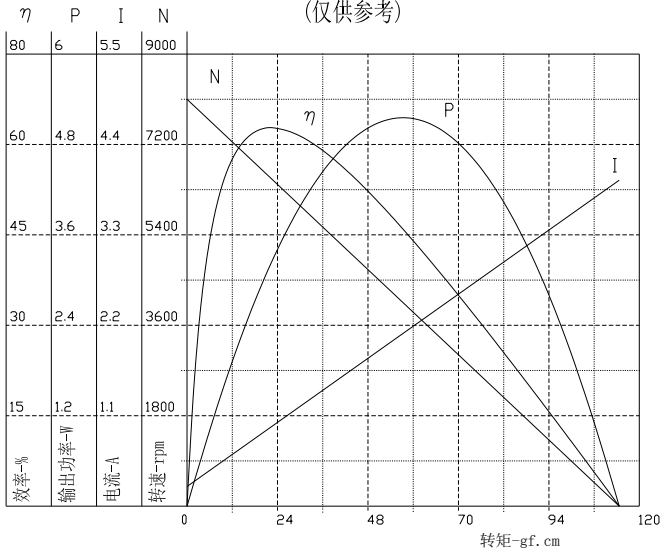

电动机的特性曲线和特性参数:

型号: **KFC-180SM-10320**

电压: **12V**

(仅供参考)

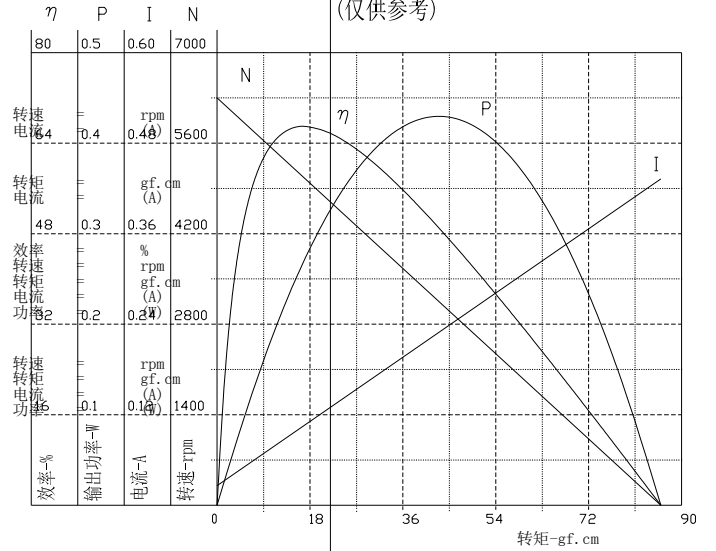

**RC-280SA OUTPUT(输出):APPROX(大概) 1.0~20W Carbon-Brushmotors(碳刷马达)**

代表用途: 精密仪器  
家用电器

Typical Application/Precision Instruments  
Household Appliances

	MODEL(型号)	VOLTAGE(电压)		NO LOAD(空载)		AT MAXIMUM EFFICIENCY (最大效率)				STALL(堵转)	
		RANGE (范围)	NOMINAL (额定)	SPEED (转速) r/min	CURRENT (电流) A	SPEED (转速) r/min	CURRENT (电流) A	TORQUE (转矩) gf.cm	OUTPUT (输出) w	TORQUE (转矩) g.cm	CURRENT (电流) A
	KRC-280SA-08360	6~24	24V CONSTANT	4000	0.03	2900	0.06	40	2	150	0.18
KRC-280SA-19150	3~24	12V CONSTANT	13000	0.09	8500	1.25	120	6	320	3.50	
KRC-280SA-3860	3~12	6.0V CONSTANT	16000	0.28	12000	2.50	100	10	310	7.50	

UNIT(单位):MILLIMETER(毫米)

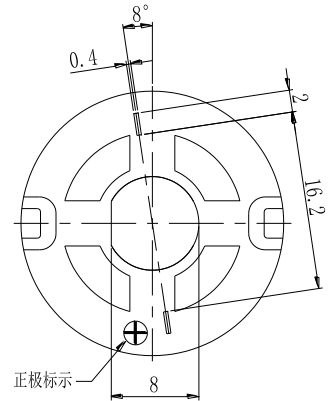
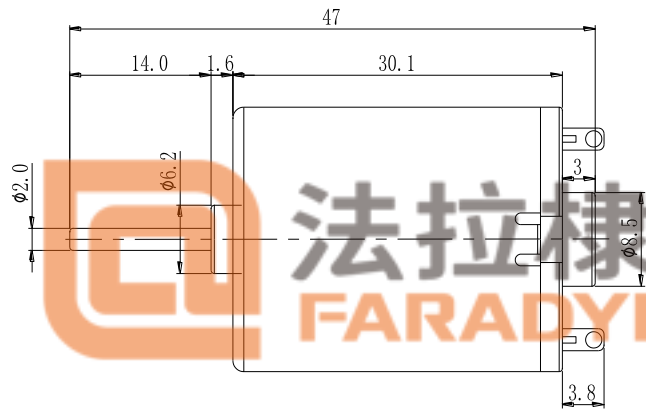
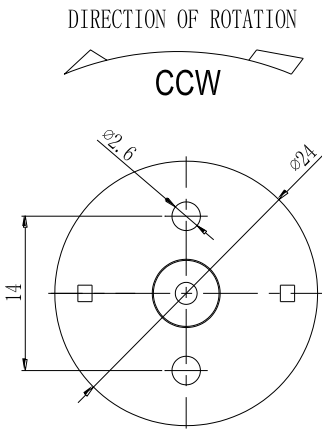

WEIGHT(重量):42g

型号: **KRC-280SA-08360**

电压: **24 V**

(仅供参考)

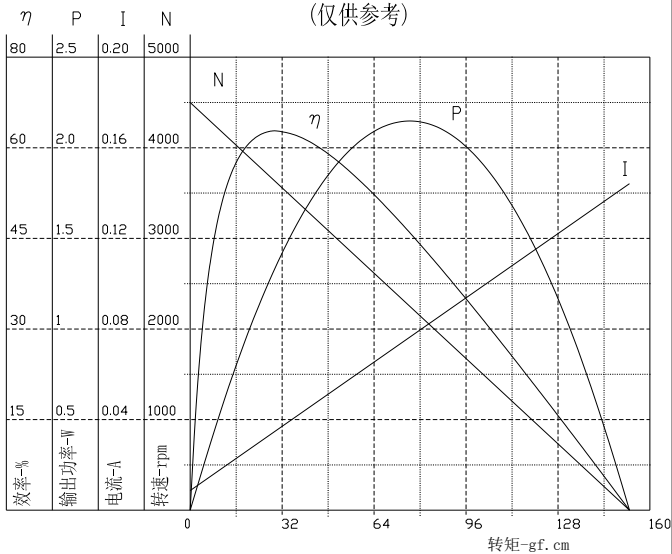

电动机的特性曲线和特性参数:

型号: **KRC-280SA-3860**

电压: **6.0V**

(仅供参考)

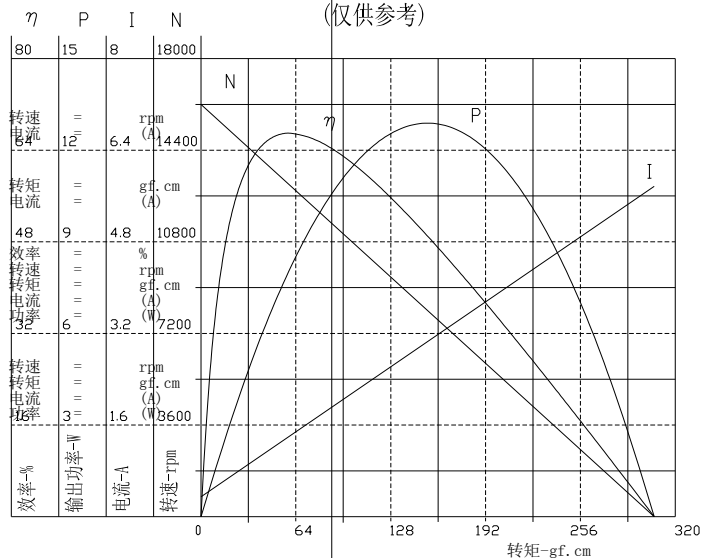

# FC-280SA OUTPUT(输出):APPROX(大概) 1.0~25W Carbon-Brushmotors(碳刷马达)

代表用途: 精密仪器  
家用电器

Typical Application/Precision Instruments  
Household Appliances

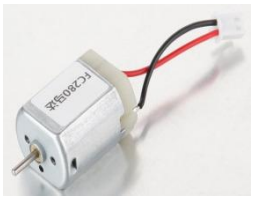
	MODEL(型号)	VOLTAGE(电压)		NO LOAD(空载)		AT MAXIMUM EFFICIENCY (最大效率)				STALL(堵转)	
		RANGE (范围)	NOMINAL (额定)	SPEED (转速) r/min	CURRENT (电流) A	SPEED (转速) r/min	CURRENT (电流) A	TORQUE (转矩) gf.cm	OUTPUT (输出) w	TORQUE (转矩) g.cm	CURRENT (电流) A
	KFC-280SA-15250	6~24	24V CONSTANT	16000	0.06	12000	1.2	100	3.0	240	3.0
KFC-280SA-16180	3~24	24V CONSTANT	12000	0.15	7000	2.0	140	4.5	350	5.0	

UNIT(单位):MILLIMETER(毫米)

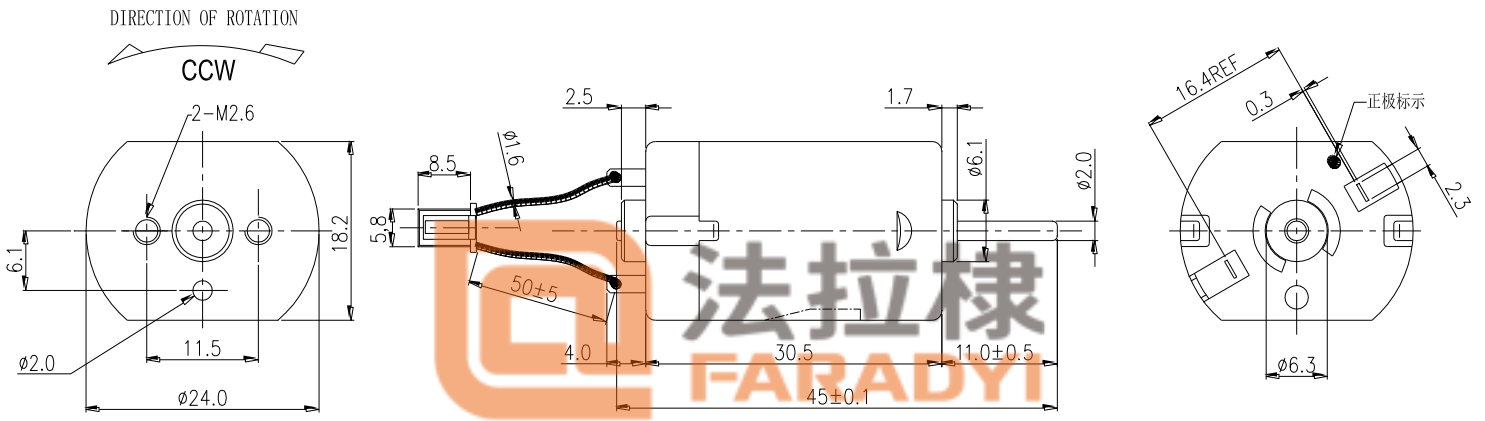

WEIGHT(重量):38g

电动机的特性曲线和特性参数:

型号: **KFC-280SA-15250**

电压: **24 V**

(仅供参考)

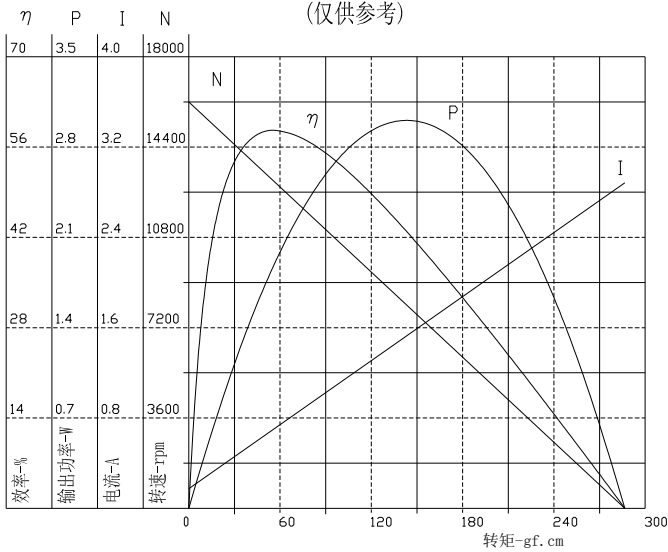

电动机的特性曲线和特性参数:

型号: **KFC-280SA-16180**

电压: **24 V**

(仅供参考)

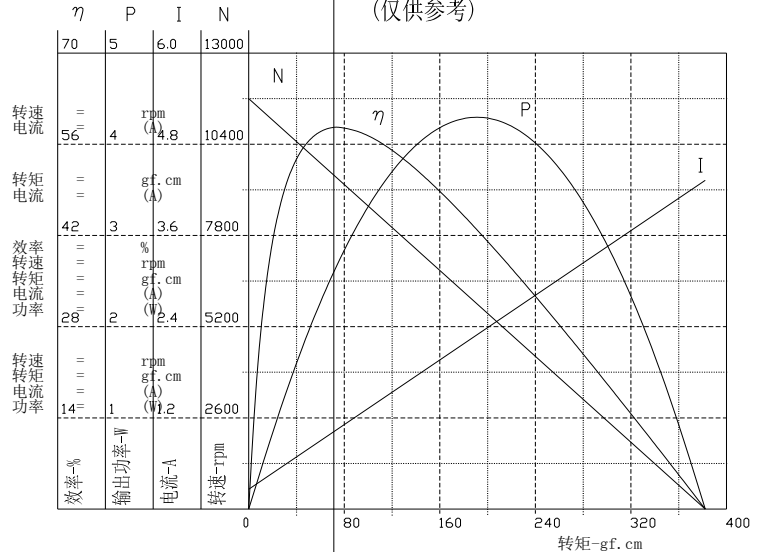

**RC-365SA OUTPUT(输出):APPROX(大概) 1.0~30W Carbon-Brushmotors(碳刷马达)**

代表用途：精密仪器  
家用电器

Typical Application/Precision Instruments  
Household Appliances

MODEL(型号)	VOLTAGE(电压)		NO LOAD(空载)		AT MAXIMUM EFFICIENCY (最大效率)				STALL(堵转)	
	RANGE (范围)	NOMINAL (额定)	SPEED (转速)	CURRENT (电流)	SPEED (转速)	CURRENT (电流)	TORQUE (转矩)	OUTPUT (输出)	TORQUE (转矩)	CURRENT (电流)
			r/min	A	r/min	A	gf.cm	w	g.cm	A
KRC-365SA-15120	6~36	24V CONSTANT	16500	0.16	12000	1.2	180	8.0	400	3.0
KRC-365SA-1880	3~24	18V CONSTANT	16000	0.20	9000	2.5	160	10.0	350	4.5
KRC-365SA-08250	6~36	24V CONSTANT	6000	0.06	4000	0.18	120	2.0	230	0.52

UNIT(单位):MILLIMETER(毫米)

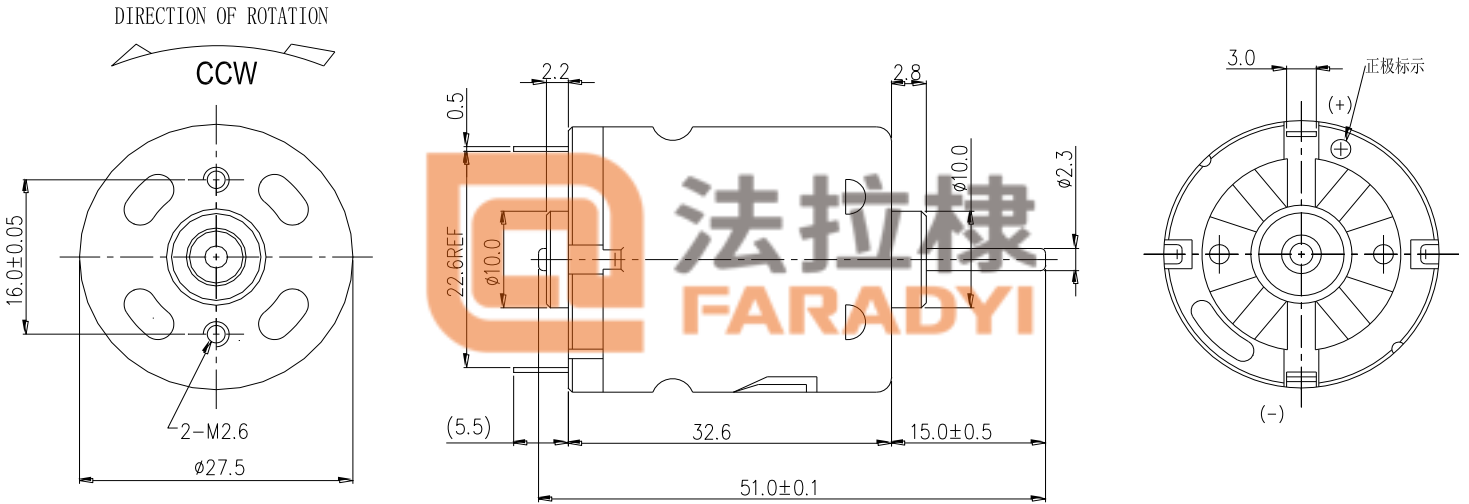

WEIGHT(重量):55g

电动机的特性曲线和特性参数:

型号: **KRC-365SA-15120**

电压: **24 V**

(仅供参考)

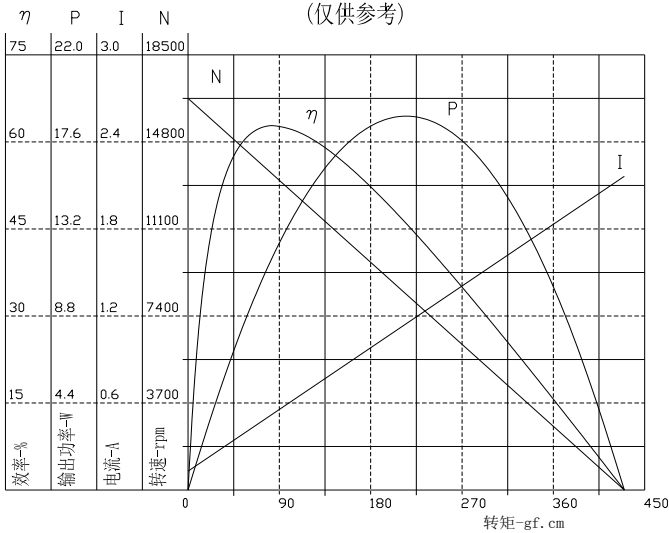

电动机的特性曲线和特性参数:

型号: **KRC-365SA-08250**

电压: **24 V**

(仅供参考)

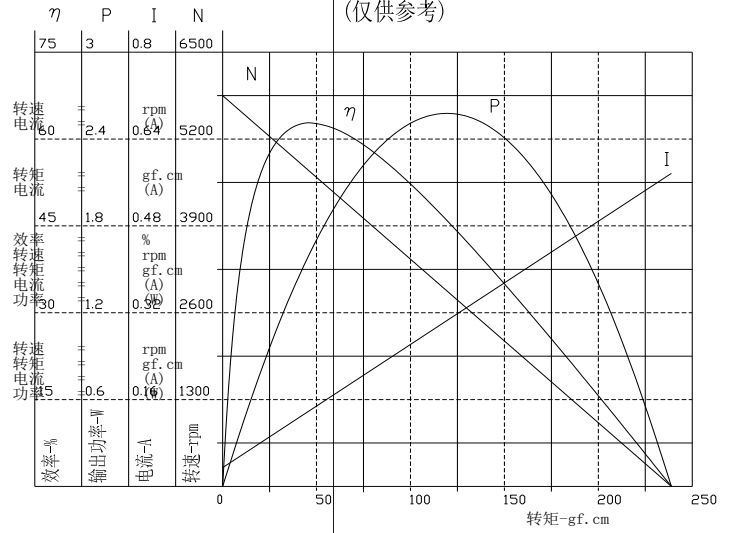

# RC-365SA OUTPUT(输出):APPROX(大概) 1.0~30W Carbon-Brushmotors(碳刷马达)

代表用途: 精密仪器  
家用电器

Typical Application/Precision Instruments  
Household Appliances

MODEL(型号)	VOLTAGE(电压)		NO LOAD(空载)		AT MAXIMUM EFFICIENCY (最大效率)				STALL(堵转)	
	RANGE (范围)	NOMINAL (额定)	SPEED (转速)	CURRENT (电流)	SPEED (转速)	CURRENT (电流)	TORQUE (转矩)	OUTPUT (输出)	TORQUE (转矩)	CURRENT (电流)
			r/min	A	r/min	A	gf.cm	w	g.cm	A
KRC-365SA-12150	6~36	24V CONSTANT	13000	0.12	9500	0.95	120	6.0	350	2.5
KRC-365SA-2272	3~24	12V CONSTANT	12000	0.15	8000	1.25	100	10.0	300	3.2

UNIT(单位):MILLIMETER(毫米)

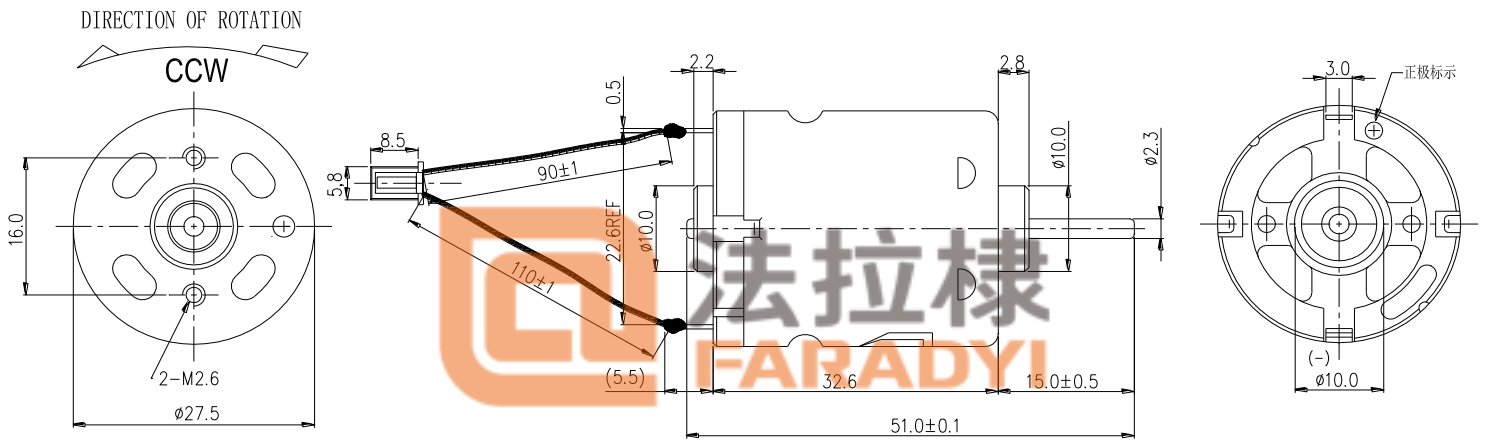

WEIGHT(重量):55g

电动机的特性曲线和特性参数:

型号: KRC-365SA-12150

电压: 24 V

(仅供参考)

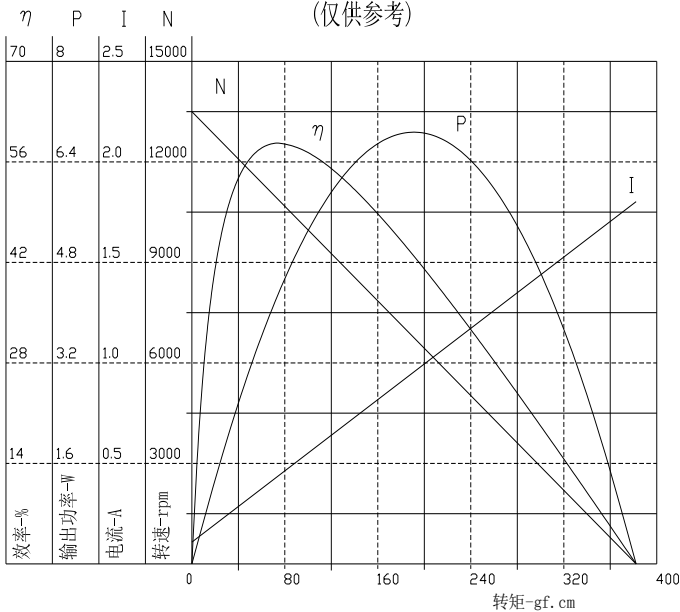

电动机的特性曲线和特性参数:

型号: KRC-365SA-2272

电压: 12V

(仅供参考)

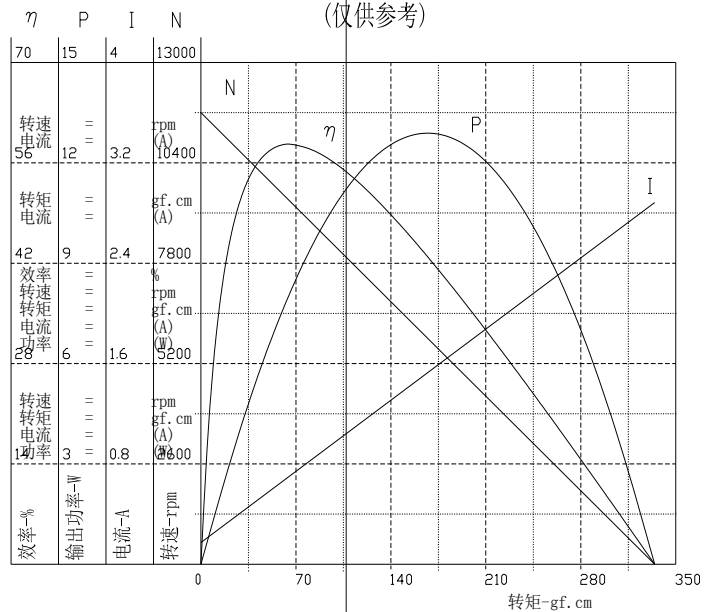

# RC-380SM OUTPUT(输出):APPROX(大概) 1.0~30W Carbon-Brushmotors(碳刷马达)

代表用途:家用电器  
电动工具

Typical Application/ Household Appliances  
Cordless Power Tools

MODEL(型号)	VOLTAGE(电压)		NO LOAD(空载)		AT MAXIMUM EFFICIENCY (最大效率)				STALL(堵转)	
	RANGE (范围)	NOMINAL (额定)	SPEED (转速)	CURRENT (电流)	SPEED (转速)	CURRENT (电流)	TORQUE (转矩)	OUTPUT (输出)	TORQUE (转矩)	CURRENT (电流)
			r/min	A	r/min	A	gf.cm	w	g.cm	A
KRC-380SM-6018	3~12	3.7V CONSTANT	16000	1.0	10000	8.0	120	20	250	28
KRC-380SM-20140	3~24	24V CONSTANT	10000	0.15	6500	0.85	260	12	350	4.8
KRC-380SM-14250	6~36	24V CONSTANT	7500	0.12	4000	0.65	200	15	280	3.0

UNIT(单位):MILLIMETER(毫米)

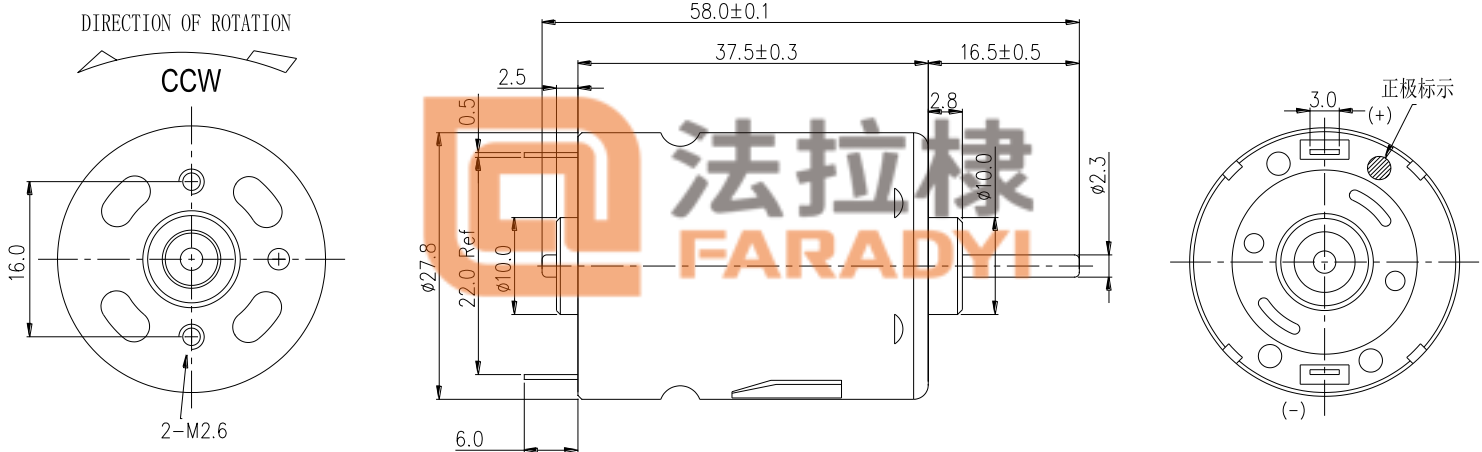

WEIGHT(重量):75g

电动机的特性曲线和特性参数:

型号: **KRC-380SM-6018**

电压: **3.7V**

(仅供参考)

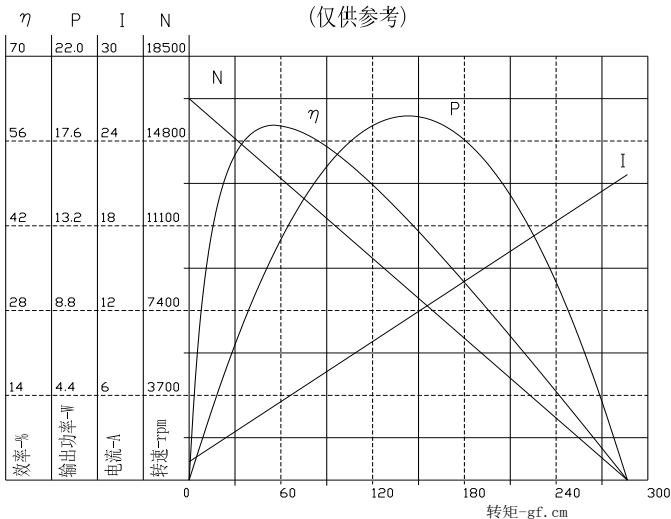

电动机的特性曲线和特性参数:

型号: **KRC-380SM-14250**

电压: **24V**

(仅供参考)

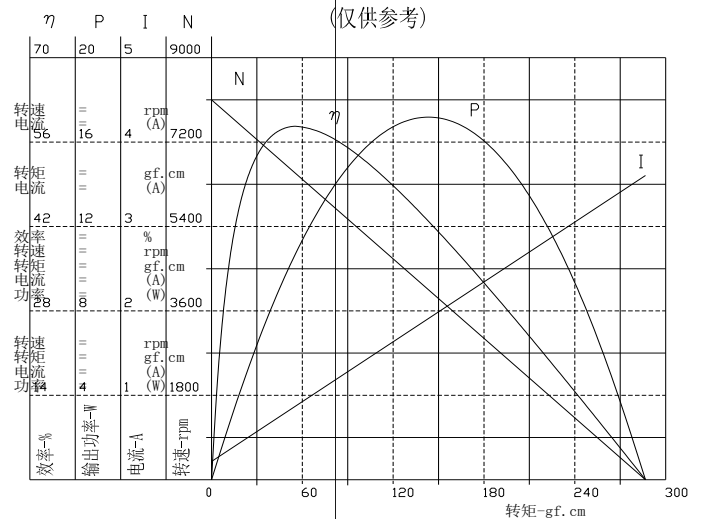

**RC-385SA** OUTPUT(输出):APPROX(大概) 1.0~30W Carbon-Brushmotors(碳刷马达)

代表用途:家用电器  
电动工具

Typical Application/ Household Appliances  
Cordless Power Tools

MODEL(型号)	VOLTAGE(电压)		NO LOAD(空载)		AT MAXIMUM EFFICIENCY (最大效率)				STALL(堵转)	
	RANGE (范围)	NOMINAL (额定)	SPEED (转速)	CURRENT (电流)	SPEED (转速)	CURRENT (电流)	TORQUE (转矩)	OUTPUT (输出)	TORQUE (转矩)	CURRENT (电流)
			r/min	A	r/min	A	gf.cm	w	g.cm	A
KRC-385SA-18100	3~36	36V CONSTANT	23000	0.15	18000	2.0	180	15	650	7.5
KRC-385SA-2073	3~36	24V CONSTANT	22000	0.18	16000	1.8	180	14	600	7.3

UNIT(单位):MILLIMETER(毫米)

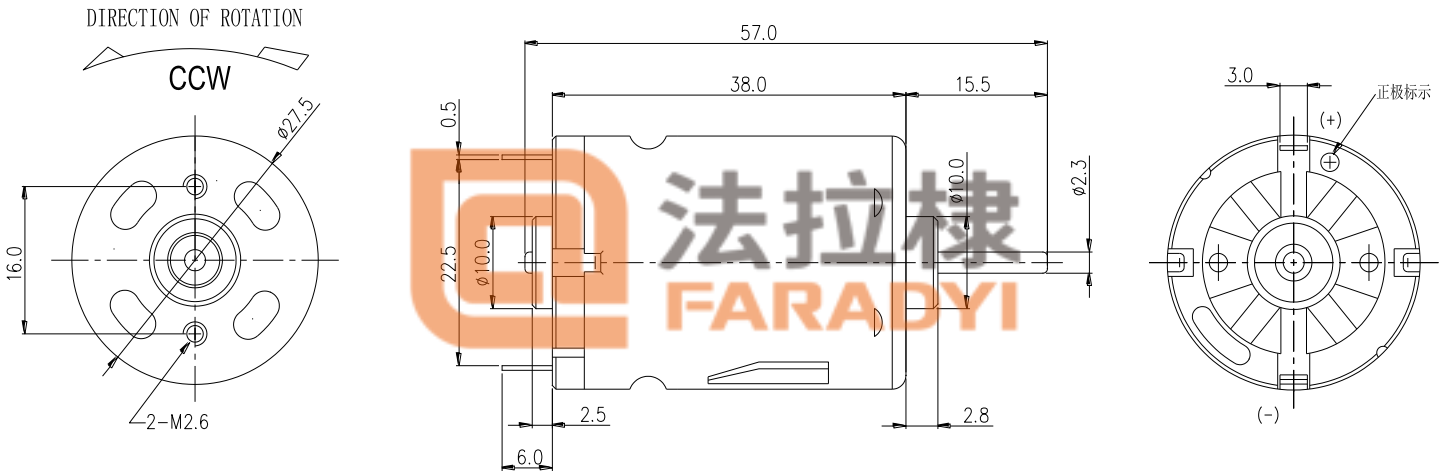

WEIGHT(重量):65g

电动机的特性曲线和特性参数:

型号: **KRC-385SA-18100**

电压: **36V**

(仅供参考)

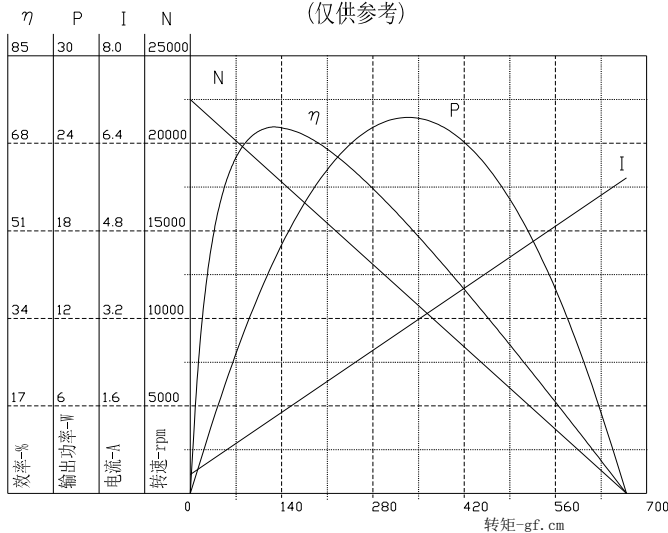

电动机的特性曲线和特性参数:

型号: **KRC-385SA-2073**

电压: **24V**

(仅供参考)

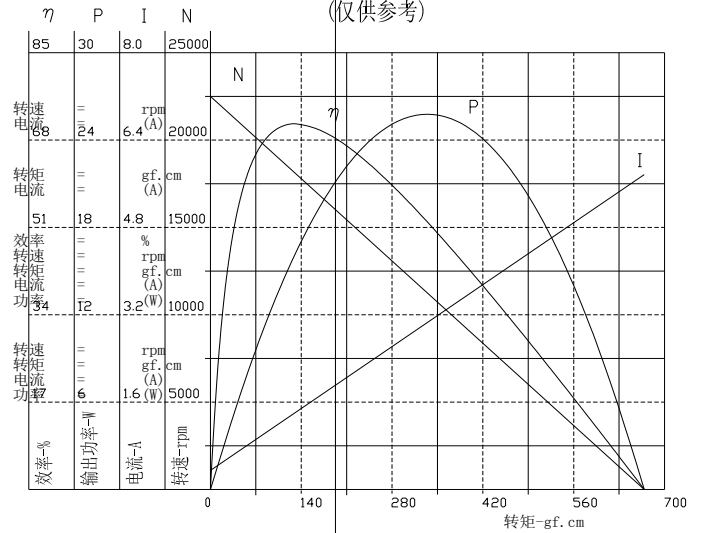



# RC-395SM OUTPUT(输出):APPROX(大概) 1.0~35W Carbon-Brushmotors(碳刷马达)

代表用途：家用电器  
电动工具

Typical Application/ Household Appliances  
Cordless Power Tools

MODEL(型号)	VOLTAGE(电压)		NO LOAD(空载)		AT MAXIMUM EFFICIENCY (最大效率)				STALL(堵转)	
	RANGE (范围)	NOMINAL (额定)	SPEED (转速)	CURRENT (电流)	SPEED (转速)	CURRENT (电流)	TORQUE (转矩)	OUTPUT (输出)	TORQUE (转矩)	CURRENT (电流)
			r/min	A	r/min	A	gf.cm	w	g.cm	A
KRC-395SM-5920	3~12	3.7V CONSTANT	13000	0.80	8000	3.5	220	35	580	9.5
KRC-395SM-16140	3~24	12V CONSTANT	3800	0.12	2800	0.95	180	8	350	1.90
KRC-395SM-1995	3~24	12V CONSTANT	4500	0.11	3500	1.20	250	20	600	3.85



UNIT(单位):MILLIMETER(毫米)

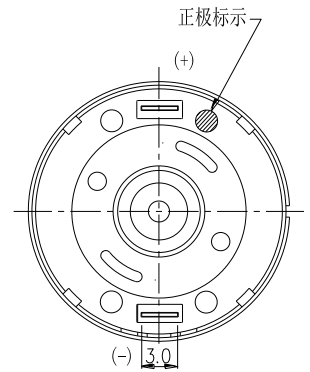
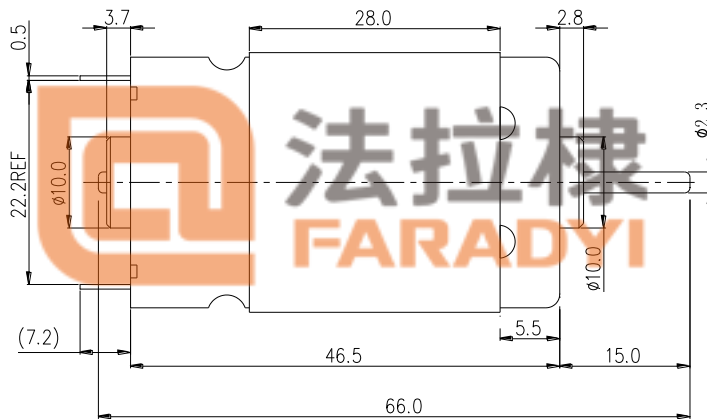
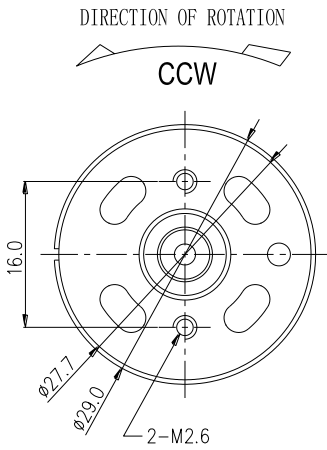

WEIGHT(重量):105g

电动机的特性曲线和特性参数:

型号: **KRC-395SM-5920**

电压: **3.7V**

(仅供参考)

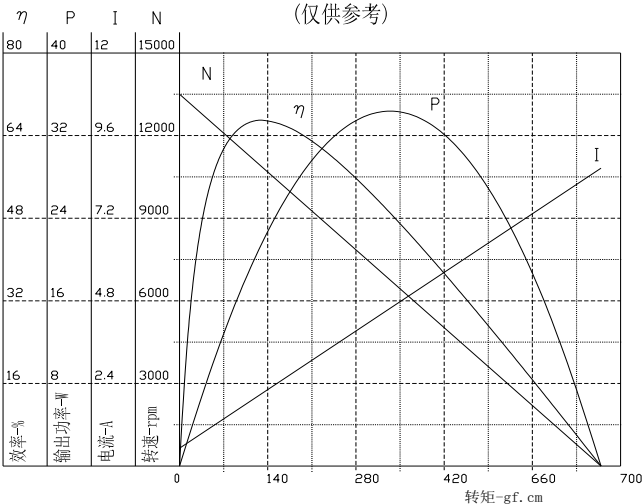

电动机的特性曲线和特性参数:

型号: **KRC-395SM-1995**

电压: **12.0V**

(仅供参考)

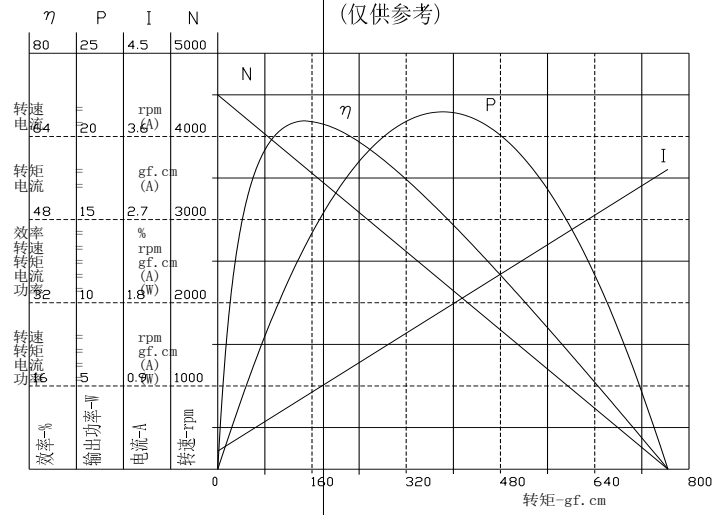

# RC-395SA OUTPUT(输出):APPROX(大概) 1.0~35W Carbon-Brushmotors(碳刷马达)

代表用途：家用电器  
电动工具

Typical Application/ Household Appliances  
Cordless Power Tools

MODEL(型号)	VOLTAGE(电压)		NO LOAD(空载)		AT MAXIMUM EFFICIENCY (最大效率)				STALL(堵转)	
	RANGE(范围)	NOMINAL(额定)	SPEED(转速)	CURRENT(电流)	SPEED(转速)	CURRENT(电流)	TORQUE(转矩)	OUTPUT(输出)	TORQUE(转矩)	CURRENT(电流)
			r/min	A	r/min	A	gf.cm	w	g.cm	A
KRC-395SA-10275	3~24	24V CONSTANT	3500	0.06	2000	0.15	100	2	160	0.30
KRC-395SA-2270	3~24	12V CONSTANT	8000	0.18	6000	1.95	200	15	500	4.5
KRC-395SA-2935	1~6	3.7V CONSTANT	4500	0.30	3300	1.20	100	12	250	5.2

UNIT(单位):MILLIMETER(毫米)

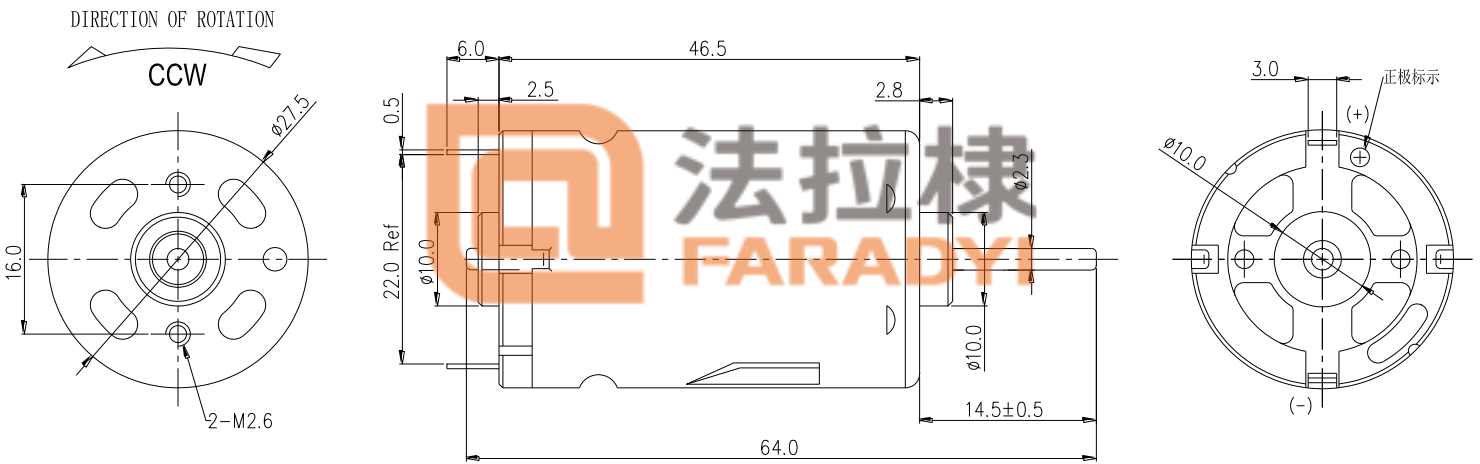

WEIGHT(重量):85g

电动机的特性曲线和特性参数:

型号: **KRC-395SA-10275**

电压: **24 V**

(仅供参考)

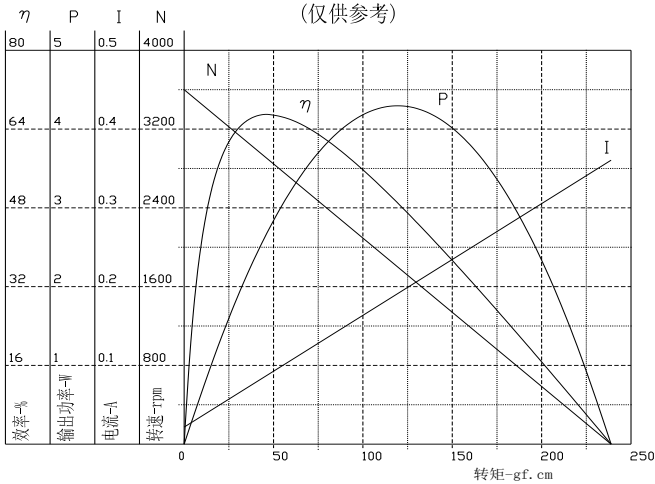

电动机的特性曲线和特性参数:

型号: **KRC-395SA-2935**

电压: **3.7V**

(仅供参考)

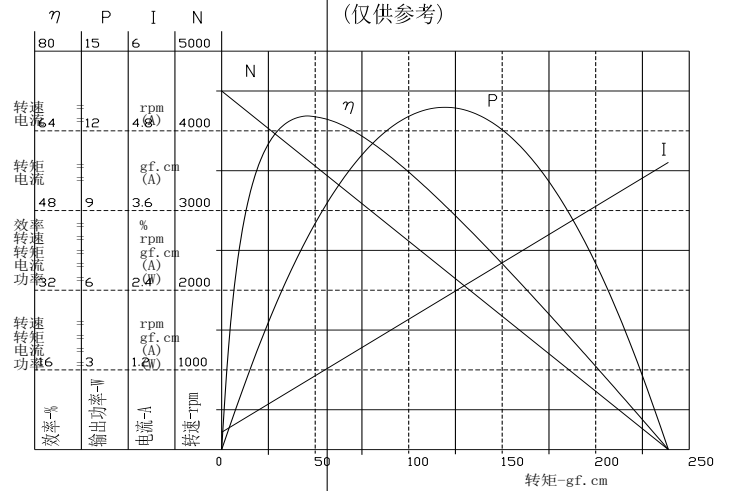

# RC-535SA OUTPUT(输出):APPROX(大概) 2.0~40W Carbon-Brushmotors(碳刷马达)

代表用途: 家用电器  
电动工具

Typical Application/ Household Appliances  
Cordless Power Tools

MODEL(型号)	VOLTAGE(电压)		NO LOAD(空载)		AT MAXIMUM EFFICIENCY (最大效率)				STALL(堵转)	
	RANGE (范围)	NOMINAL (额定)	SPEED (转速)	CURRENT (电流)	SPEED (转速)	CURRENT (电流)	TORQUE (转矩)	OUTPUT (输出)	TORQUE (转矩)	CURRENT (电流)
			r/min	A	r/min	A	gf.cm	w	g.cm	A
KRC-535SA-18160	3~24	12V CONSTANT	8000	0.15	6000	0.50	300	8	600	1.8
KRC-535SA-3550	3~12	6V CONSTANT	9000	0.20	5000	2.20	280	15	550	7.5
KRC-535SA-24105	3~36	36V CONSTANT	5000	0.15	3000	1.80	350	30	800	5.0

UNIT(单位):MILLIMETER(毫米)

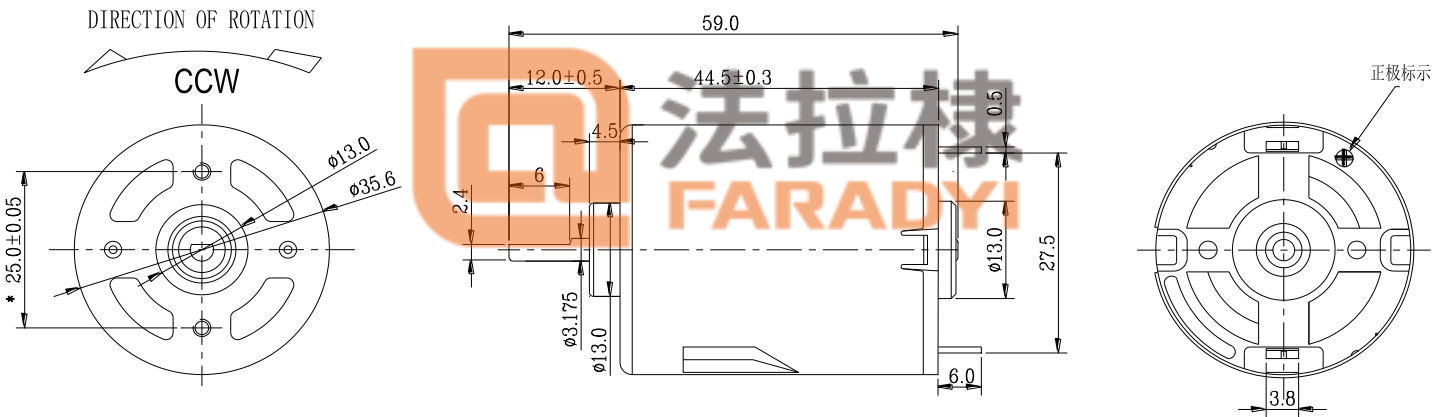

WEIGHT(重量):135g

电动机的特性曲线和特性参数:

型号: **KRC-535SA-18160**

电压: **12.0V**

(仅供参考)

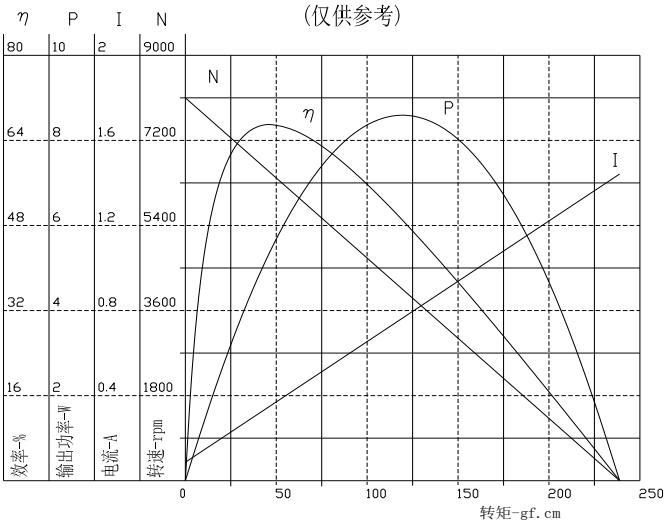

电动机的特性曲线和特性参数:

型号: **KRC-535SA-24105**

电压: **36.0V**

(仅供参考)

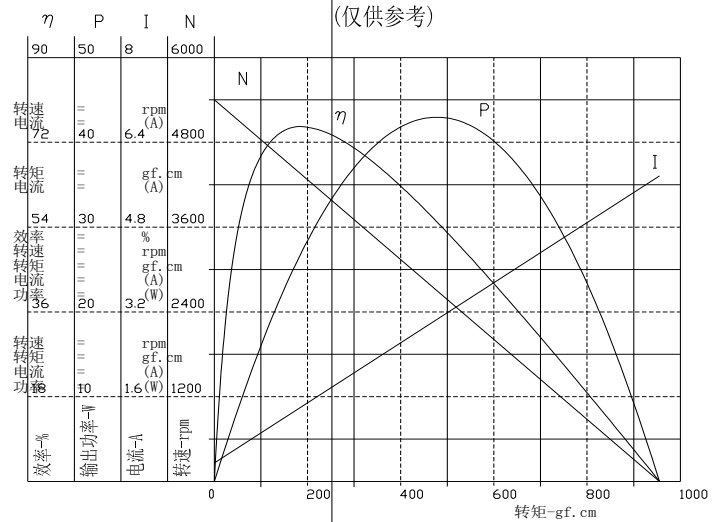

# RC-540SM OUTPUT(输出):APPROX(大概) 2.0~50W Carbon-Brushmotors(碳刷马达)

代表用途：家用电器  
电动工具

Typical Application/ Household Appliances  
Cordless Power Tools

MODEL(型号)	VOLTAGE(电压)		NO LOAD(空载)		AT MAXIMUM EFFICIENCY (最大效率)				STALL(堵转)	
	RANGE(范围)	NOMINAL(额定)	SPEED(转速)	CURRENT(电流)	SPEED(转速)	CURRENT(电流)	TORQUE(转矩)	OUTPUT(输出)	TORQUE(转矩)	CURRENT(电流)
			r/min	A	r/min	A	gf.cm	w	g.cm	A
KRC-540SM-8014	3~12	3.7V CONSTANT	16500	2.20	10500	12.5	220	25	500	28
KRC-540SM-5545	3~12	12V CONSTANT	10000	0.80	6500	4.15	300	18	800	9
KRC-540SM-16400	12~36	24V CONSTANT	4500	0.05	3000	0.20	120	8	350	1.8

UNIT(单位):MILLIMETER(毫米)

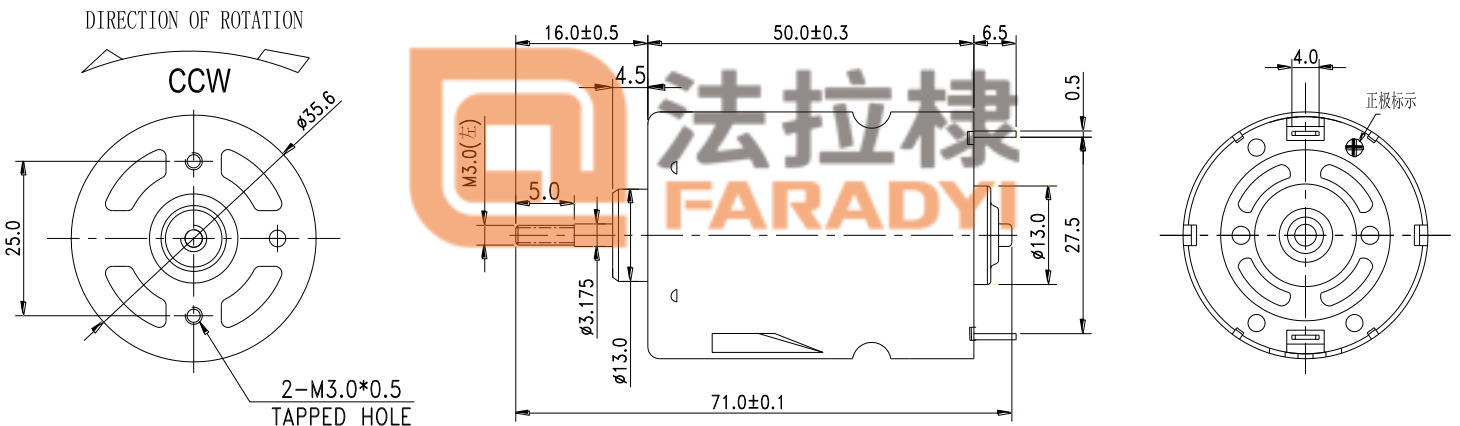

WEIGHT(重量):155g

电动机的特性曲线和特性参数:

型号: **KRC-540SM-5545**

电压: **12.0V**

(仅供参考)

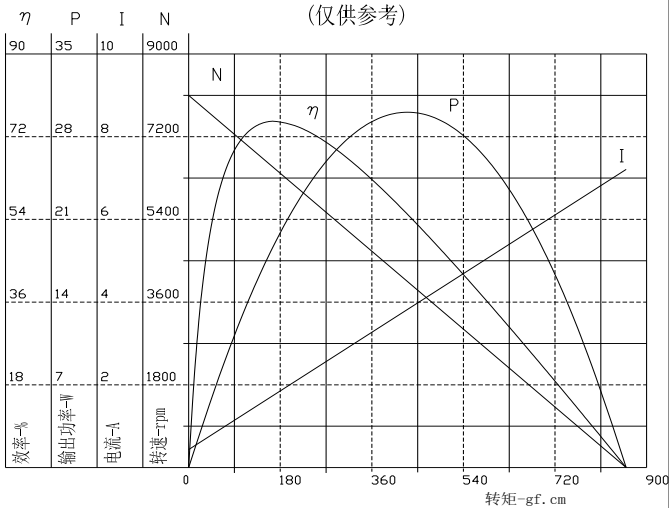

电动机的特性曲线和特性参数:

型号: **KRC-540SM-8014**

电压: **3.7V**

(仅供参考)

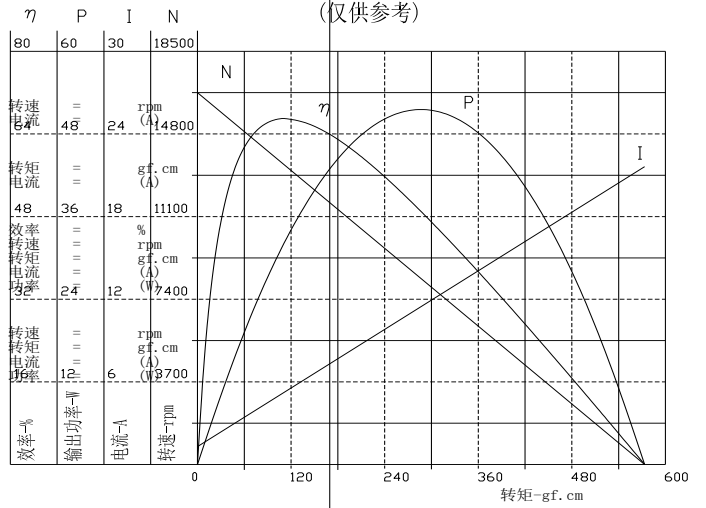

# RC-555SA OUTPUT(输出):APPROX(大概) 3.0~60W Carbon-Brushmotors(碳刷马达)

代表用途：家用电器  
电动工具

Typical Application/ Household Appliances  
Cordless Power Tools

MODEL(型号)	VOLTAGE(电压)		NO LOAD(空载)		AT MAXIMUM EFFICIENCY (最大效率)				STALL(堵转)	
	RANGE (范围)	NOMINAL (额定)	SPEED (转速)	CURRENT (电流)	SPEED (转速)	CURRENT (电流)	TORQUE (转矩)	OUTPUT (输出)	TORQUE (转矩)	CURRENT (电流)
			r/min	A	r/min	A	gf.cm	w	g.cm	A
KRC-555SA-2284	3~24	24V CONSTANT	6500	0.08	3500	2.5	300	18	900	6.5
KRC-555SA-20150	3~24	24V CONSTANT	4500	0.06	3800	1.5	250	13	600	5
KRC-555SA-8010	3~12	3.7V CONSTANT	18000	2.5	12500	20	350	42	750	45

UNIT(单位):MILLIMETER(毫米)

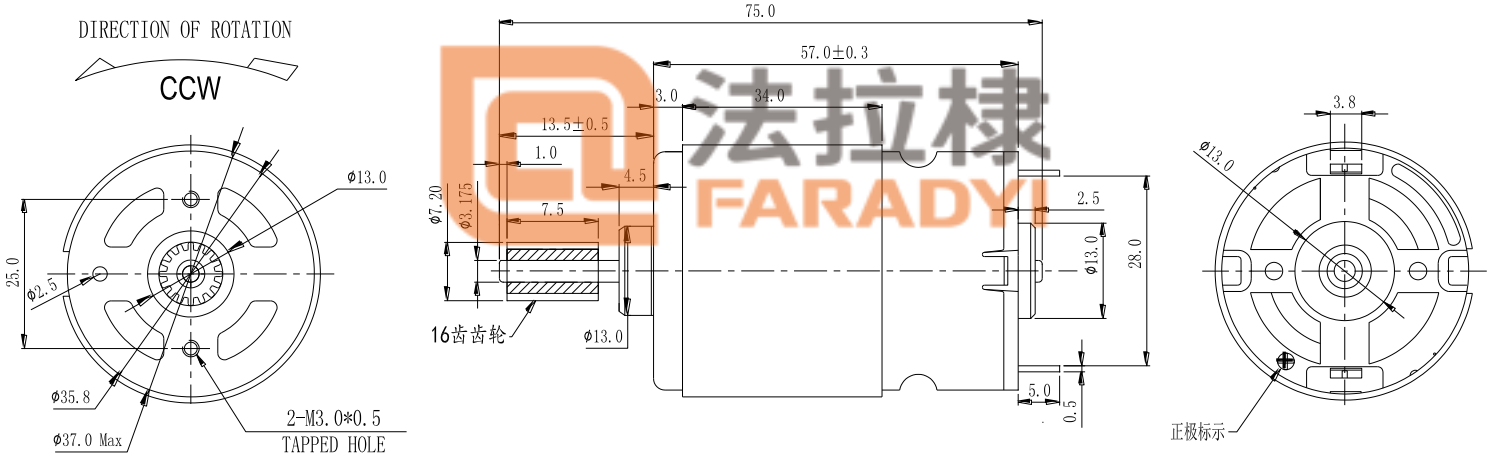

WEIGHT(重量):200g

电动机的特性曲线和特性参数:

型号: **KRC-555SA-2284**

电压: **24.0V**

(仅供参考)

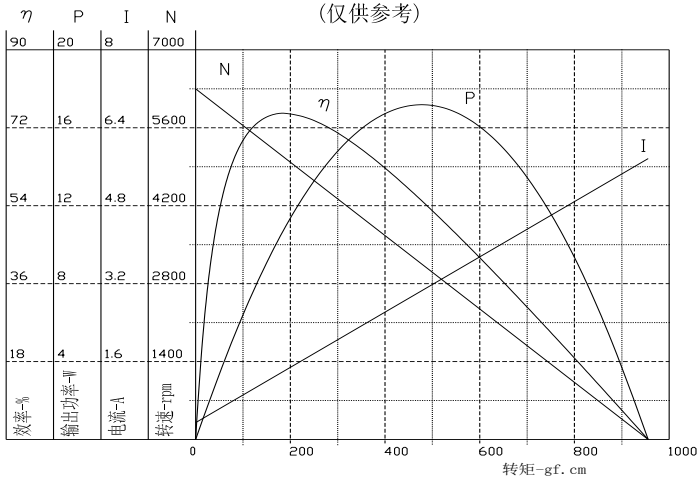

电动机的特性曲线和特性参数:

型号: **KRC-555SM-8010**

电压: **3.7V**

(仅供参考)

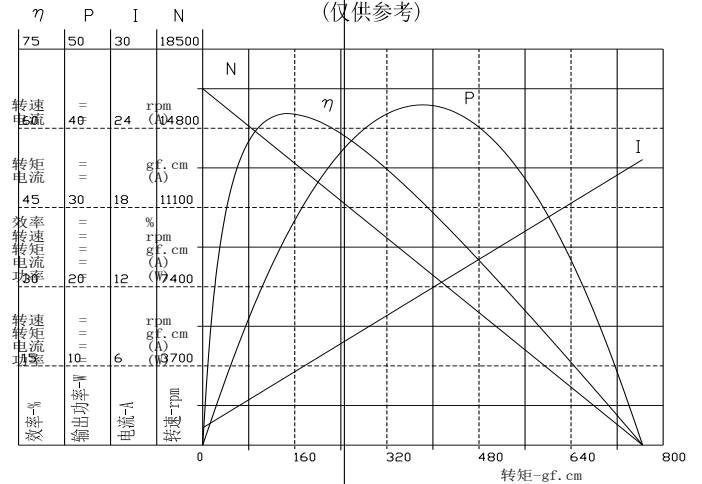

**RC-560SM OUTPUT(输出):APPROX(大概) 3.0~60W Carbon-Brushmotors(碳刷马达)**

代表用途：家用电器  
电动工具

Typical Application/ Household Appliances  
Cordless Power Tools

MODEL(型号)	VOLTAGE(电压)		NO LOAD(空载)		AT MAXIMUM EFFICIENCY (最大效率)				STALL(堵转)	
	RANGE (范围)	NOMINAL (额定)	SPEED (转速)	CURRENT (电流)	SPEED (转速)	CURRENT (电流)	TORQUE (转矩)	OUTPUT (输出)	TORQUE (转矩)	CURRENT (电流)
			r/min	A	r/min	A	gf.cm	w	g.cm	A
KRC-560SM-37105	3~24	12V CONSTANT	4500	0.12	2800	3.0	450	20	1200	6
KRC-560SM-20250	3~24	24V CONSTANT	5000	0.05	3000	1.2	280	12	900	3
KRC-560SM-5045	3~12	12V CONSTANT	9000	0.65	5000	4.0	600	25	1500	9

UNIT(单位):MILLIMETER(毫米)

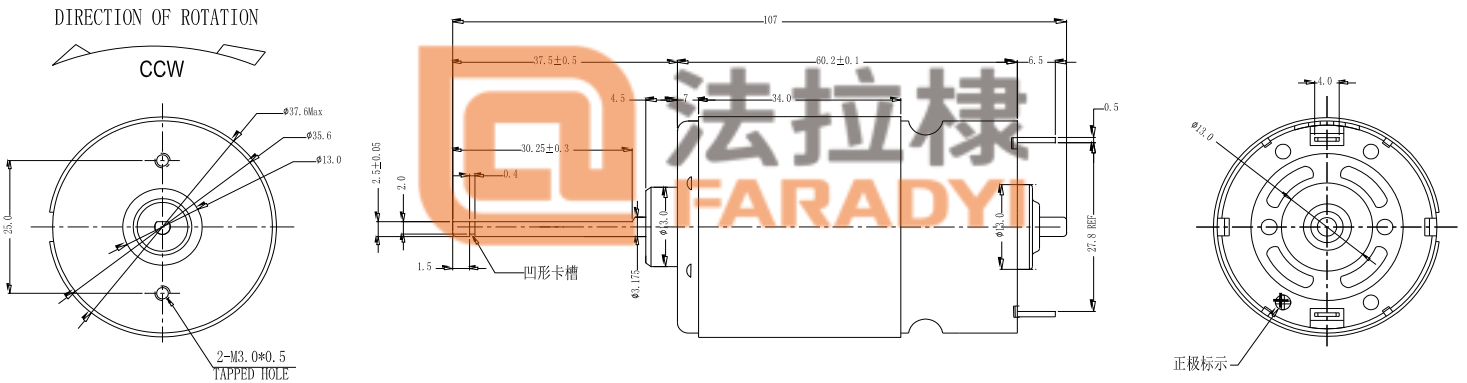

WEIGHT(重量):240g

电动机的特性曲线和特性参数:

型号: **KRC-560SM-37105**

电压: **12.0V**

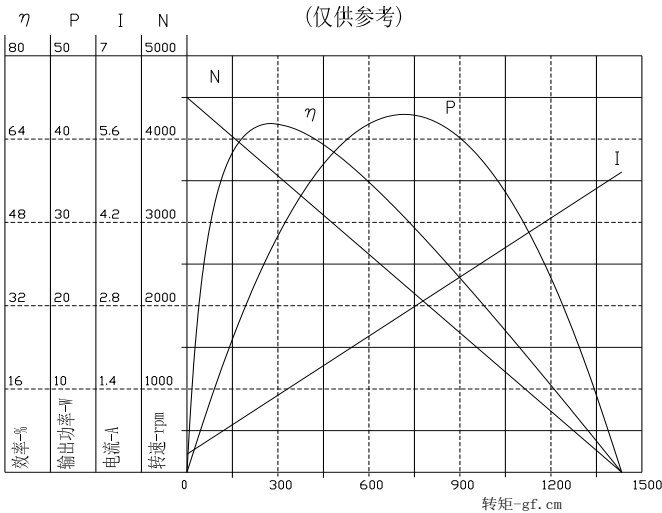

电动机的特性曲线和特性参数:

型号: **KRC-560SM-5045**

电压: **12.0V**

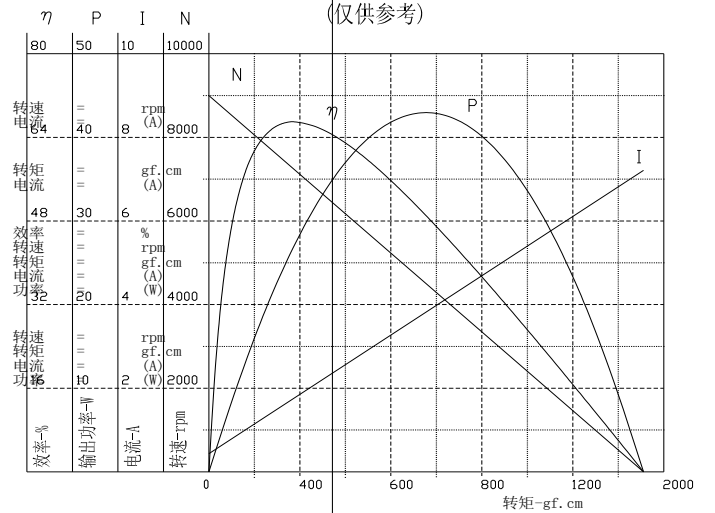

# RC-5512SA OUTPUT(输出):APPROX(大概) 15~200W Carbon-Brushmotors(碳刷马达)

代表用途: 精密仪器  
家用电器

Typical Application/Precision Instruments  
Household Appliances

	MODEL(型号)	VOLTAGE(电压)		NO LOAD(空载)		AT MAXIMUM EFFICIENCY (最大效率)				STALL(堵转)	
		RANGE (范围)	NOMINAL (额定)	SPEED (转速)	CURRENT (电流)	SPEED (转速)	CURRENT (电流)	TORQUE (转矩)	OUTPUT (输出)	TORQUE (转矩)	CURRENT (电流)
				r/min	A	r/min	A	gf.cm	w	g.cm	A
	RC-5512SA-08250	120~240	230V CONSTANT	10000	0.08	7500	1.5	800	35	2000	3.5
	RC-5512SA-1970	120~240	120V CONSTANT	12000	0.11	8500	2.0	600	120	1800	4.5

UNIT(单位):MILLIMETER(毫米)

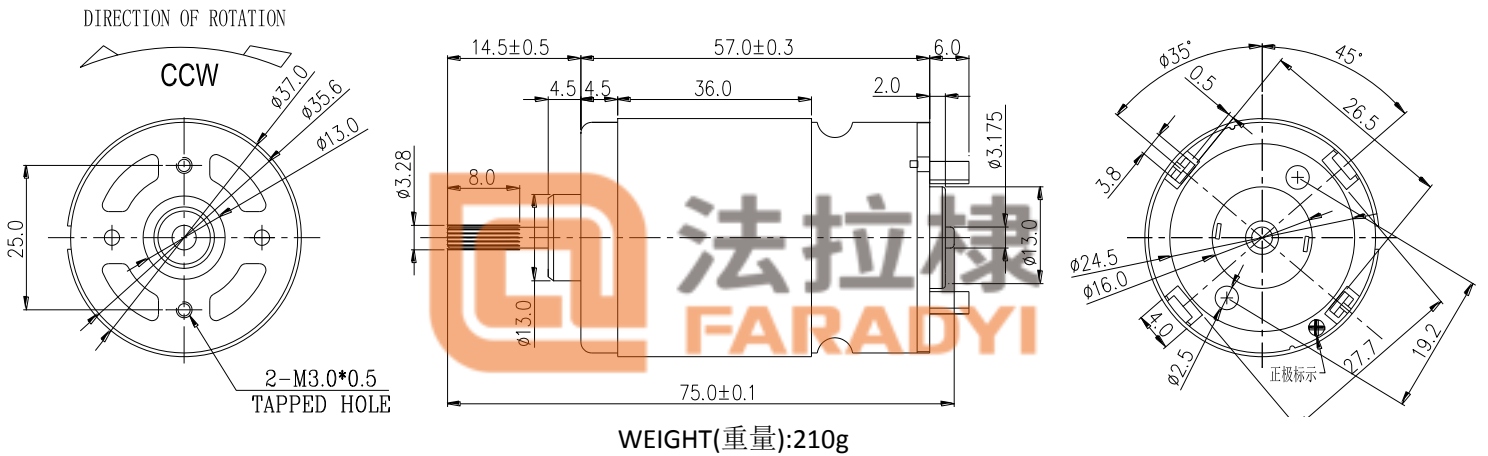

电动机的特性曲线和特性参数:

型号: RC-5512SA-08250

电压: 230V

(仅供参考)

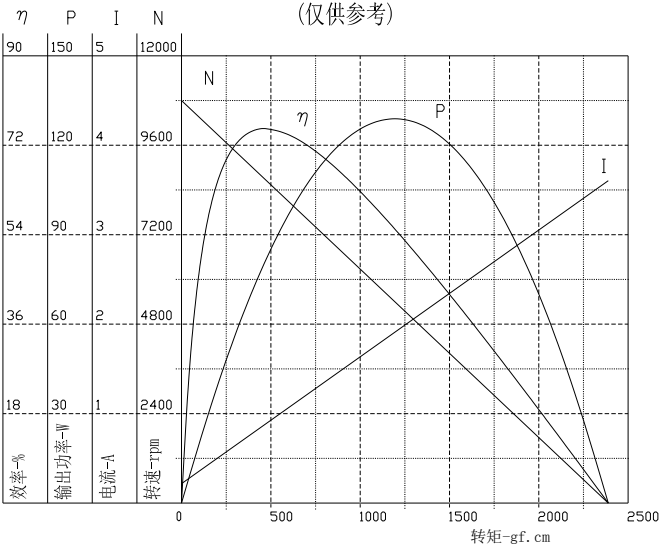

电动机的特性曲线和特性参数:

型号: RC-5512SA-1970

电压: 120V

(仅供参考)

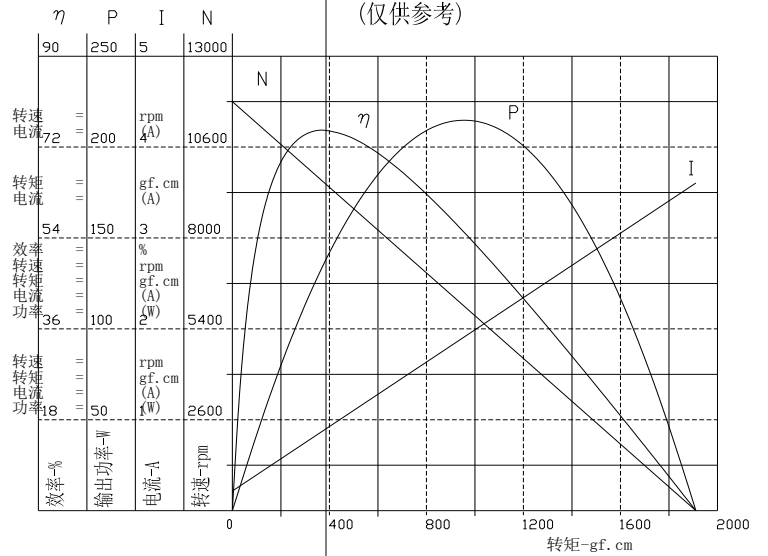

# RC-755SM OUTPUT(输出):APPROX(大概) 6.0~90W Carbon-Brushmotors(碳刷马达)

代表用途：家用电器  
电动工具

Typical Application/ Household Appliances  
Cordless Power Tools

MODEL(型号)	VOLTAGE(电压)		NO LOAD(空载)		AT MAXIMUM EFFICIENCY (最大效率)				STALL(堵转)	
	RANGE (范围)	NOMINAL (额定)	SPEED (转速)	CURRENT (电流)	SPEED (转速)	CURRENT (电流)	TORQUE (转矩)	OUTPUT (输出)	TORQUE (转矩)	CURRENT (电流)
			r/min	A	r/min	A	gf.cm	w	g.cm	A
KRC-755SM-31105	3~24	12V CONSTANT	2000	0.15	1300	1.0	500	30	1100	2.95
KRC-755SM-29110	3~24	12V CONSTANT	2000	0.13	1200	0.9	450	25	1050	2.80
KRC-755SM-4045	3~12	12V CONSTANT	10000	0.80	7000	2.65	600	40	1400	8.0

UNIT(单位):MILLIMETER(毫米)

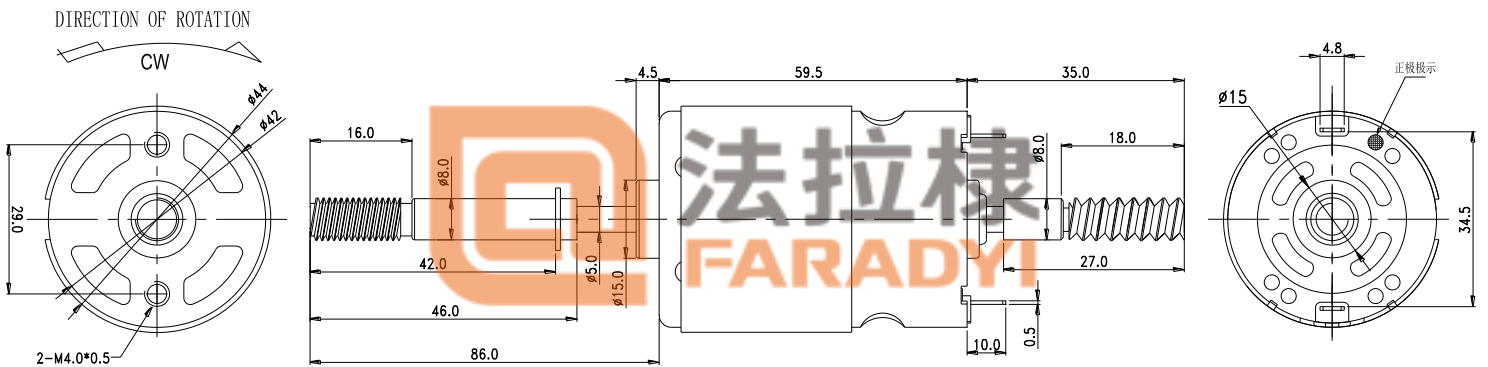

WEIGHT(重量):320g

电动机的特性曲线和特性参数:

型号: **KRC-755SM-31105**

电压: **12.0V**

(仅供参考)

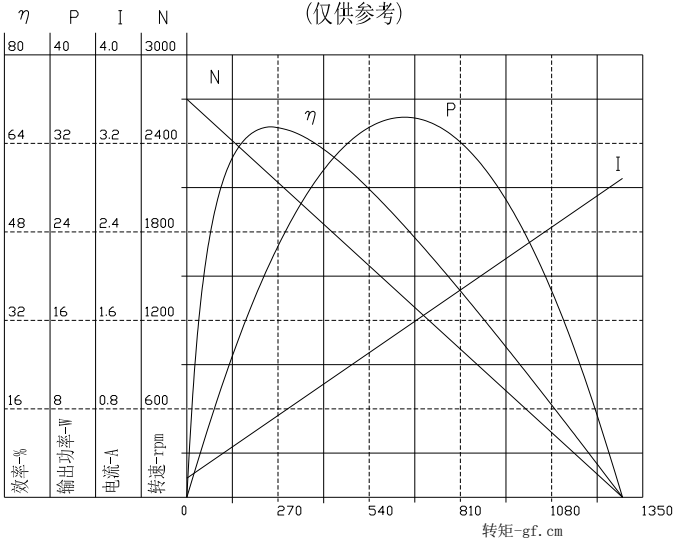

电动机的特性曲线和特性参数:

型号: **KRC-755SM-4045**

电压: **12.0V**

(仅供参考)

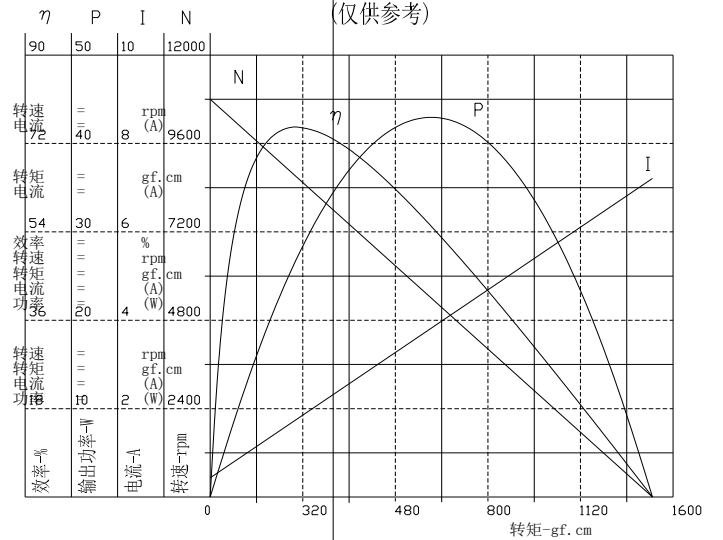



**RC-755SM OUTPUT(输出):APPROX(大概) 6.0~90W Carbon-Brushmotors(碳刷马达)**

代表用途：家用电器  
电动工具  
搅拌机

Typical Application/ Household Appliances  
Cordless Power Tools  
Agitator

	MODEL(型号)	VOLTAGE(电压)		NO LOAD(空载)		AT MAXIMUM EFFICIENCY (最大效率)				STALL(堵转)	
		RANGE (范围)	NOMINAL (额定)	SPEED (转速)	CURRENT (电流)	SPEED (转速)	CURRENT (电流)	TORQUE (转矩)	OUTPUT (输出)	TORQUE (转矩)	CURRENT (电流)
				r/min	A	r/min	A	gf.cm	w	g.cm	A
	KRC-755M-4260	3~24	12V CONSTANT	8000	0.23	5800	2.5	600	25	1350	6.2
	KRC-755SM-4545	3~24	12V CONSTANT	10000	0.25	7800	2.8	750	32	1650	8.0

UNIT(单位):MILLIMETER(毫米)

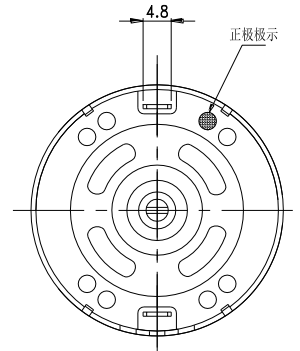
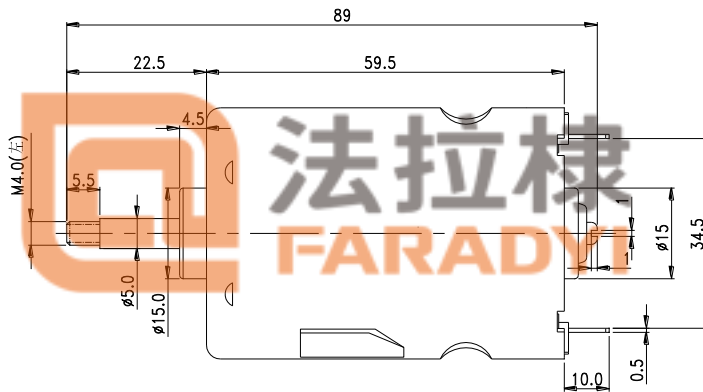
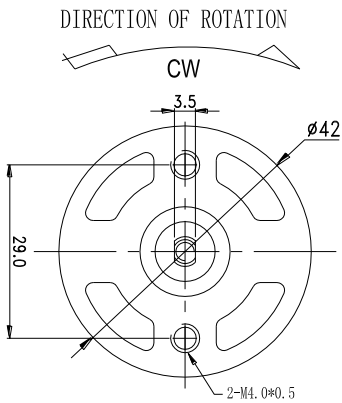

WEIGHT(重量):280g

电动机的特性曲线和特性参数:

型号: **KRC-755M-4260**

电压: **12.0V**

(仅供参考)

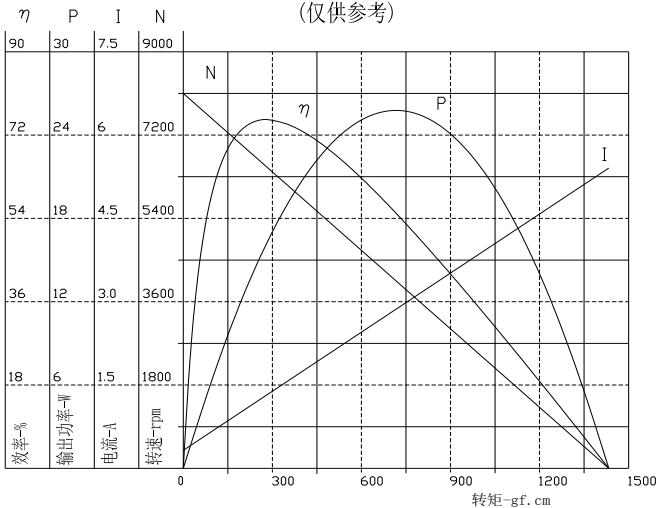

电动机的特性曲线和特性参数:

型号: **KRC-755SM-4545**

电压: **12V**

(仅供参考)

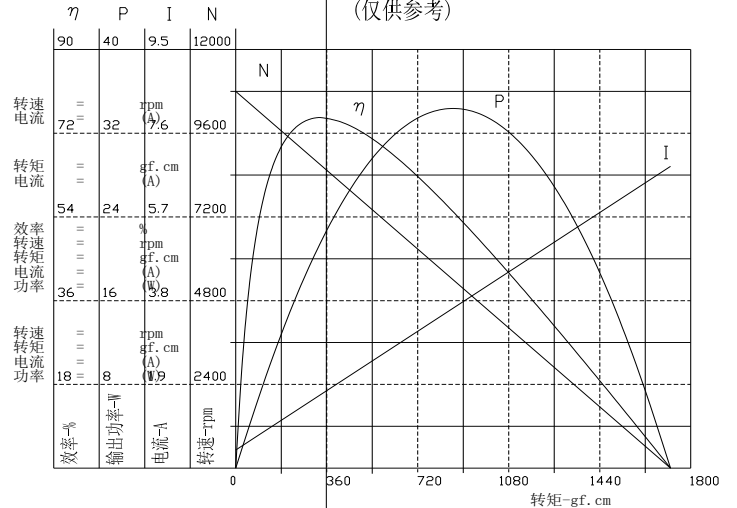

**RC-775SM OUTPUT(输出):APPROX(大概) 6.0~90W Carbon-Brushmotors(碳刷马达)**

代表用途：家用电器  
电动工具

Typical Application/ Household Appliances  
Cordless Power Tools

MODEL(型号)	VOLTAGE(电压)		NO LOAD(空载)		AT MAXIMUM EFFICIENCY (最大效率)				STALL(堵转)	
	RANGE (范围)	NOMINAL (额定)	SPEED (转速)	CURRENT (电流)	SPEED (转速)	CURRENT (电流)	TORQUE (转矩)	OUTPUT (输出)	TORQUE (转矩)	CURRENT (电流)
			r/min	A	r/min	A	gf.cm	w	g.cm	A
KRC-775M-3393	3~24	12V CONSTANT	2200	0.16	1200	1.2	650	30	1400	3.2
KRC-775M-3570	3~24	24V CONSTANT	9200	0.32	7900	1.96	800	40	3000	12
KRC-775M-7513	6-15	12V CONSTANT	18500	2.20	16000	13.6	1200	117	5000	40



UNIT(单位):MILLIMETER(毫米)

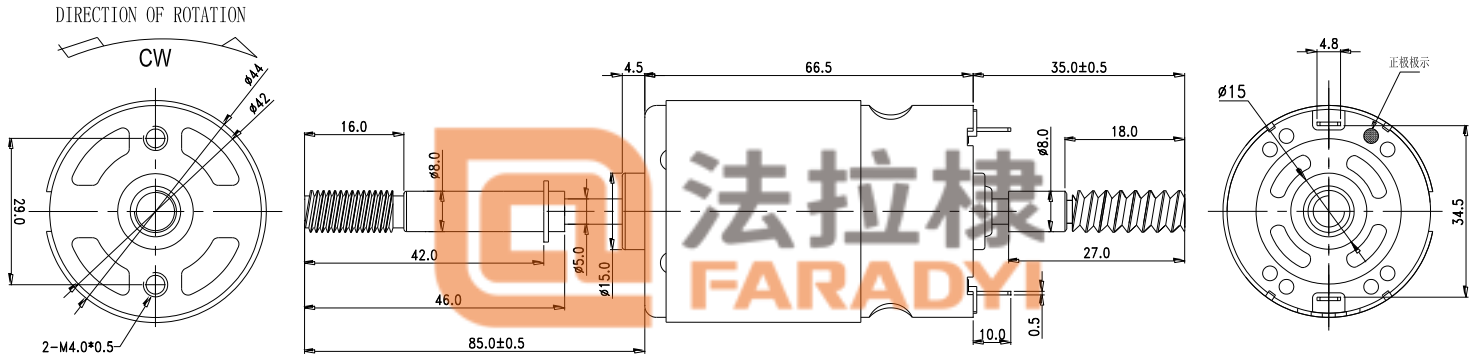

WEIGHT(重量):390g

电动机的特性曲线和特性参数:

型号: **KRC-775SM-3393**

电压: **12.0V**

(仅供参考)

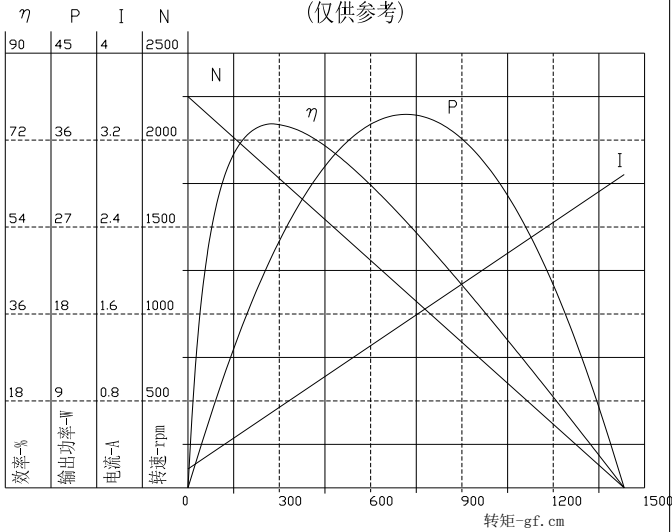

电动机的特性曲线和特性参数:

型号: **KRC-775SM-7513**

电压: **12.0V**

(仅供参考)

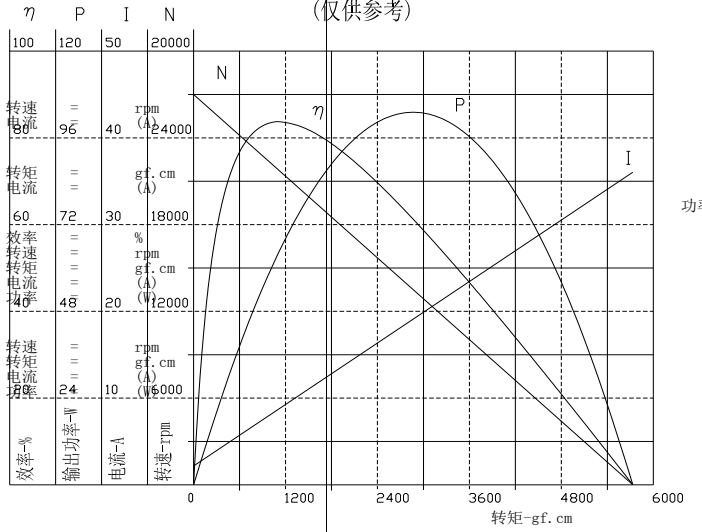

**RC-775SM OUTPUT(输出):APPROX(大概) 6.0~90W Carbon-Brushmotors(碳刷马达)**

代表用途：家用电器  
电动工具  
吸尘器

Typical Application/ Household Appliances  
Cordless Power Tools  
Vacuum Cleaner

MODEL(型号)	VOLTAGE(电压)		NO LOAD(空载)		AT MAXIMUM EFFICIENCY (最大效率)				STALL(堵转)	
	RANGE (范围)	NOMINAL (额定)	SPEED (转速)	CURRENT (电流)	SPEED (转速)	CURRENT (电流)	TORQUE (转矩)	OUTPUT (输出)	TORQUE (转矩)	CURRENT (电流)
			r/min	A	r/min	A	gf.cm	w	g.cm	A
KRC-775M-8510	3~12	12V CONSTANT	20000	1.2	16500	4.0	1000	35	3200	15
KRC-775SM-3395	3~24	24V CONSTANT	8000	0.23	5800	1.2	650	15.3	2000	3.5



UNIT(单位):MILLIMETER(毫米)

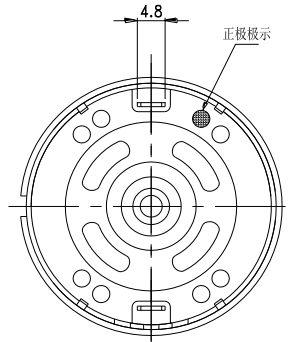
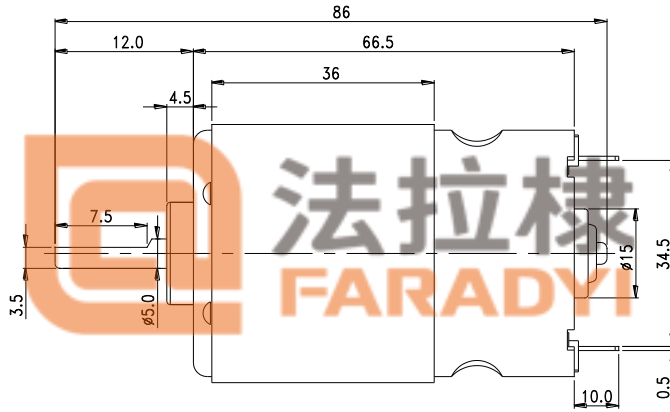
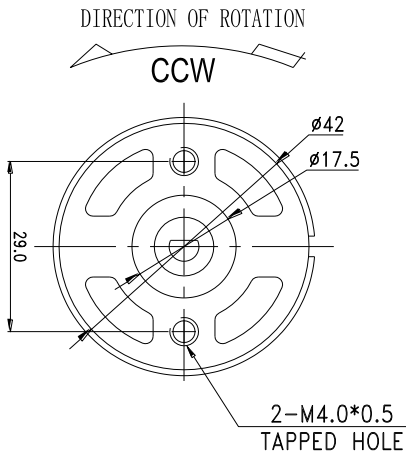

WEIGHT(重量):360g

电动机的特性曲线和特性参数:

型号: **KRC-775M-8510**

电压: **12.0V**

(仅供参考)

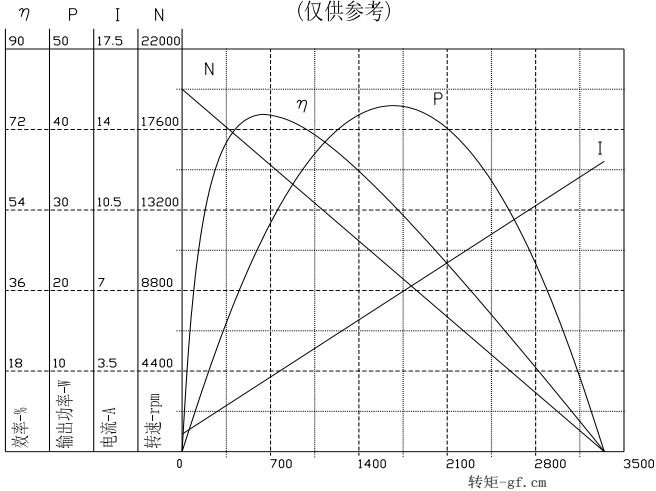

电动机的特性曲线和特性参数:

型号: **KRC-775SM-3395**

电压: **24V**

(仅供参考)

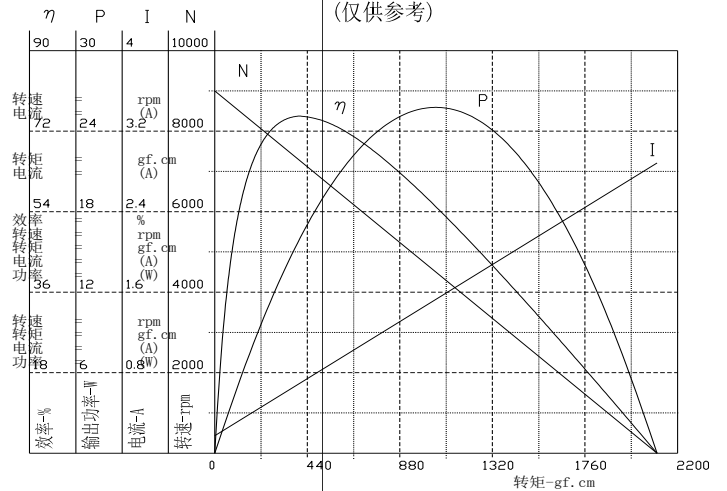

**RC-8112** OUTPUT(输出):APPROX(大概) 15~300W Carbon-Brushmotors(碳刷马达)

代表用途: 精密仪器  
家用电器

Typical Application/Precision Instruments  
Household Appliances

	VOLTAGE(电压)		NO LOAD(空载)		AT MAXIMUM EFFICIENCY (最大效率)				STALL(堵转)		
	MODEL(型号)	RANGE (范围)	NOMINAL (额定)	SPEED (转速)	CURRENT (电流)	SPEED (转速)	CURRENT (电流)	TORQUE (转矩)	OUTPUT (输出)	TORQUE (转矩)	CURRENT (电流)
				r/min	A	r/min	A	gf.cm	w	g.cm	A
RC-8112-16140	120~240	230V CONSTANT	8000	0.10	6800	1.8	1500	200	4000	4.2	
RC-8112-2175	120~240	120V CONSTANT	10000	0.12	7500	2.3	1400	180	3500	5.0	

UNIT(单位):MILLIMETER(毫米)

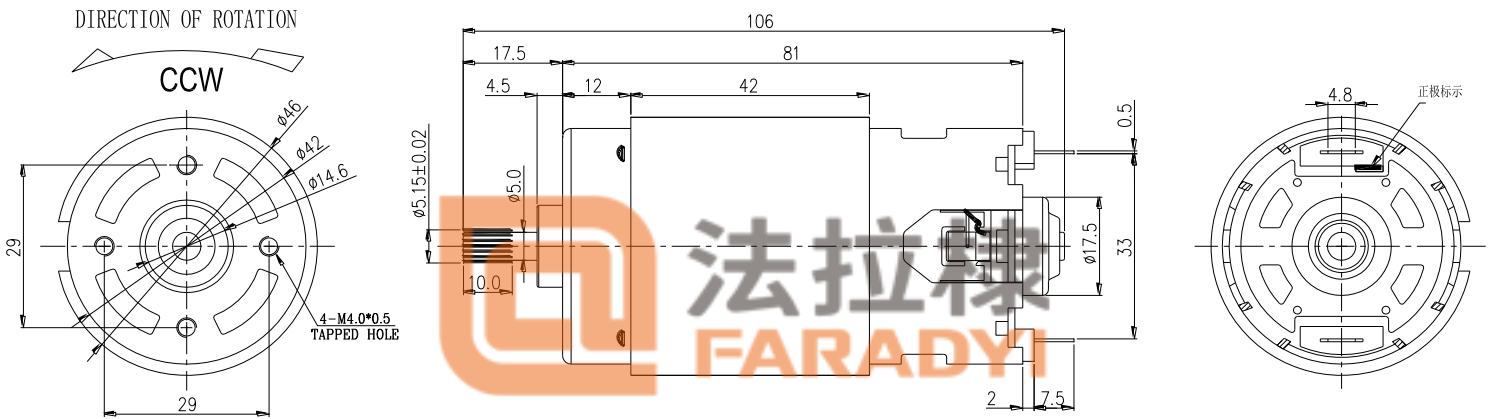

WEIGHT(重量):460g

电动机的特性曲线和特性参数:

型号: RC-8112-16140

电压: 230V

(仅供参考)

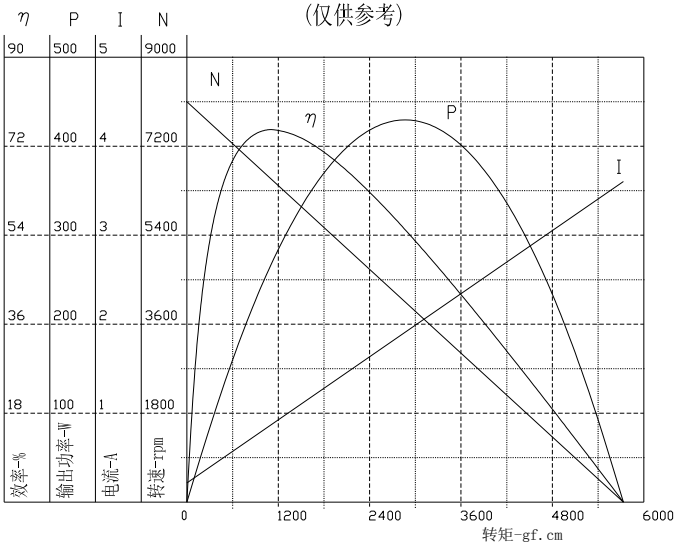

电动机的特性曲线和特性参数:

型号: RC-8112-2175

电压: 120V

(仅供参考)

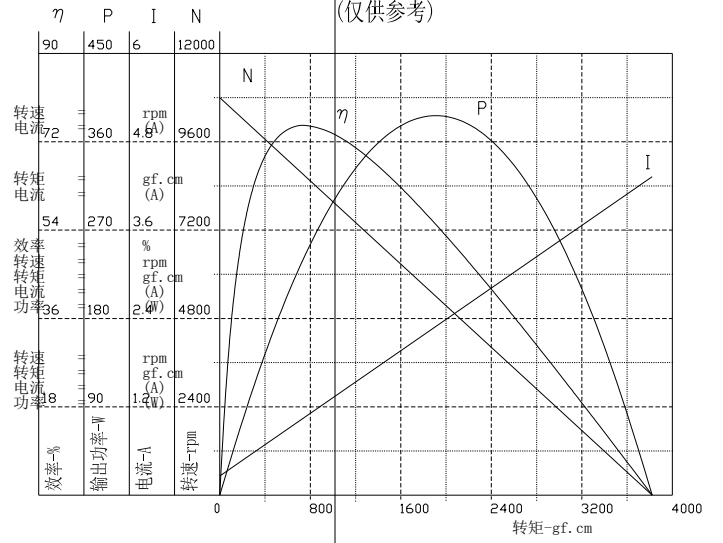

**RC3427** OUTPUT(输出):APPROX(大概) 5.0~150W Carbon-Brushmotors(碳刷马达)

代表用途: 精密仪器  
家用电器

Typical Application/Precision Instruments  
Household Appliances

MODEL(型号)	VOLTAGE(电压)		NO LOAD(空载)		AT MAXIMUM EFFICIENCY (最大效率)				STALL(堵转)	
	RANGE (范围)	NOMINAL (额定)	SPEED (转速)	CURRENT (电流)	SPEED (转速)	CURRENT (电流)	TORQUE (转矩)	OUTPUT (输出)	TORQUE (转矩)	CURRENT (电流)
			r/min	A	r/min	A	gf.cm	w	g.cm	A
KRC-3427-DC(3219)	6~24	12V CONSTANT	2500	0.12	1550	2.0	550	20	1500	5.0
KRC-3427-AC(15100)	120~240	240V CONSTANT	10000	0.10	8000	1.5	800	85	1800	4.0

UNIT(单位):MILLIMETER(毫米)

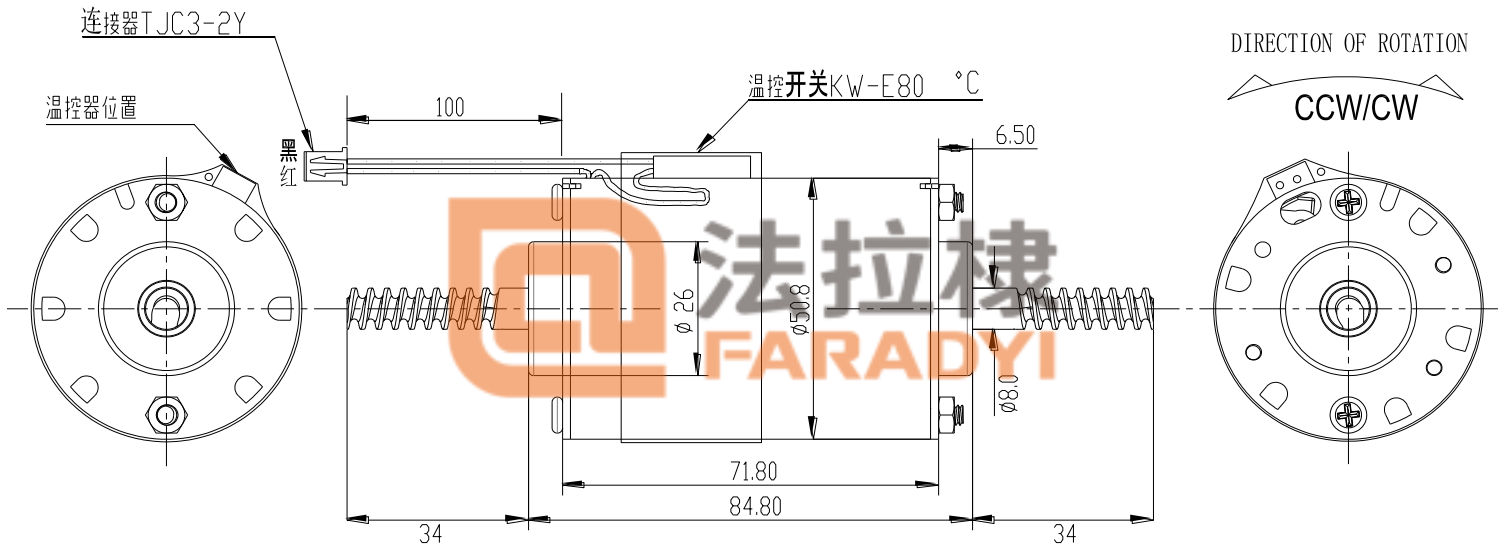

WEIGHT(重量):530g

电动机的特性曲线和特性参数:

型号: **KRC-3427-DC(3219)**

电压: **12V**

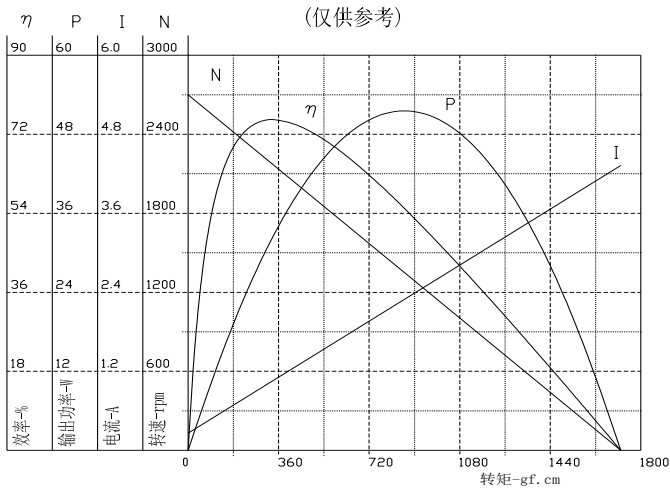

电动机的特性曲线和特性参数:

型号: **KRC-3427-AC(15100)**

电压: **240V**

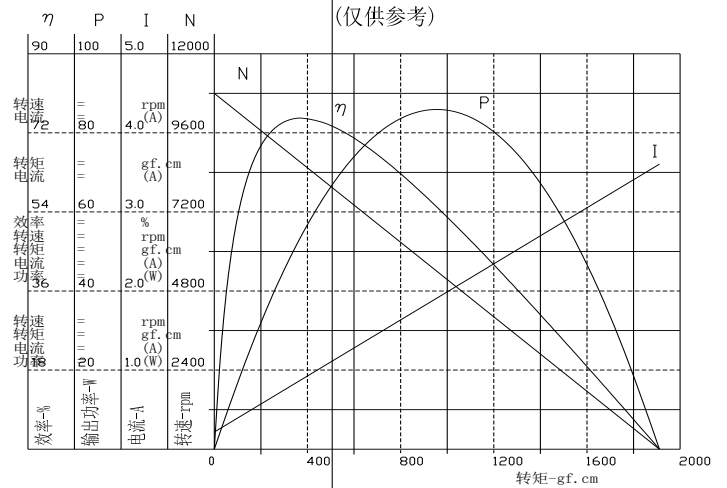

**FC3470 OUTPUT(输出):APPROX(大概) 5.0~145W Carbon-Brushmotors(碳刷马达)**

代表用途: 精密仪器  
家用电器

Typical Application/Precision Instruments  
Household Appliances

MODEL(型号)	VOLTAGE(电压)		NO LOAD(空载)		AT MAXIMUM EFFICIENCY (最大效率)				STALL(堵转)	
	RANGE (范围)	NOMINAL (额定)	SPEED (转速)	CURRENT (电流)	SPEED (转速)	CURRENT (电流)	TORQUE (转矩)	OUTPUT (输出)	TORQUE (转矩)	CURRENT (电流)
			r/min	A	r/min	A	gf.cm	w	g.cm	A
KFC-3470-AC(20105)	120~240	220V CONSTANT	4800	0.18	3800	1.2	800	28	2000	4.5
KFC-3470-AC(3045)	120~240	120V CONSTANT	5200	0.30	4500	2.5	650	35	1800	8.5

UNIT(单位):MILLIMETER(毫米)

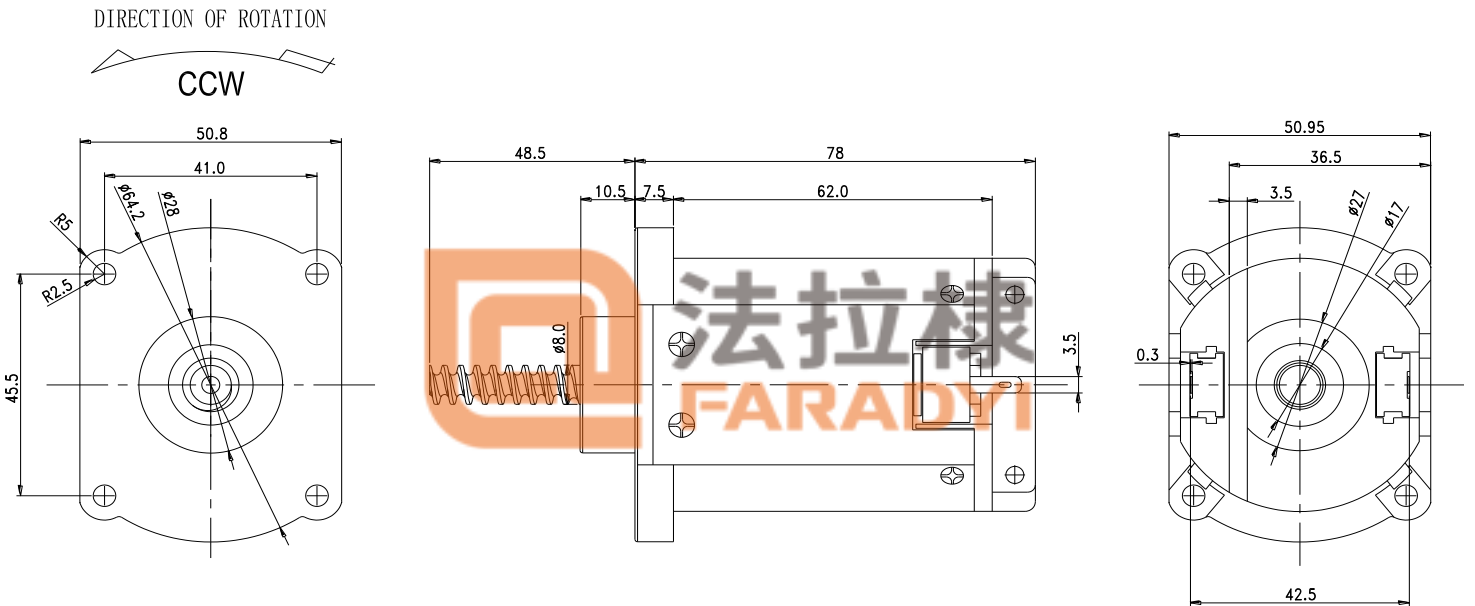

WEIGHT(重量):465g

电动机的特性曲线和特性参数:

型号: **KFC-3470-AC(20105)**

电压: **220V**

(仅供参考)

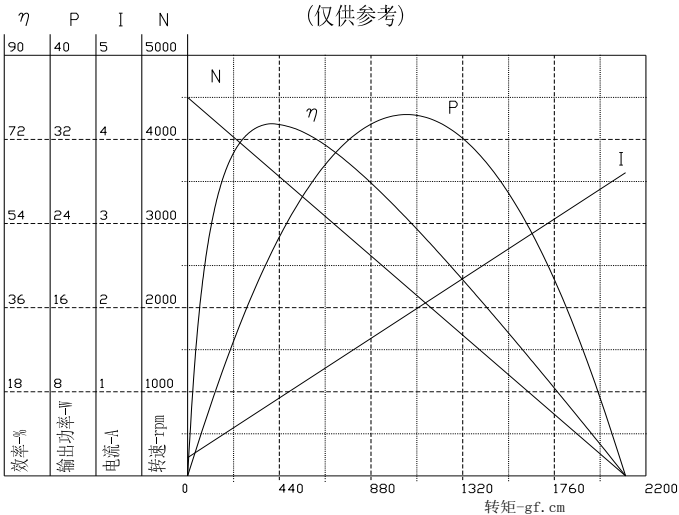

电动机的特性曲线和特性参数:

型号: **KFC-3470-AC(3045)**

电压: **120V**

(仅供参考)

