

产品目录Product Menu

1.有刷直流电机系列 Brushed Dc Motor Series

1.1有刷直流电机 Brushed Dc Motors

30ZYT Series	01
32ZYN Series	02
38ZYN Series	03
42ZYT Series	04
52ZYT Series	05
52ZYT-High Speed Series	06
54ZYT Series	07
63ZYT Series	08
76ZYT Series	09
80ZYT Series	10
80ZYT-R Replaceable Brushes Series	11
90ZYT Series	12

1.2有刷直流行星减速电机 Brushed Dc Planetary Gear Motors

36JXE30K.38ZYN Series	13
42JXE100K.42ZYT Series	14
42JXGT200K.42ZYT Series	15
52JXE300K.52ZYT Series	16
56JXE300K.63ZYT Series	17
60JXE450K.76ZYT Series	18
60JXE450K.80ZYT Series	19
82PN.90ZYT Series	20

1.3有刷直流涡轮蜗杆减速电机 Brushed Dc Worm Gear Motors

WG5882.42ZYT Series	21
63WG.63ZYT Series	22
NMRV30.80ZYT Series	23
NMRV40.80ZYT Series	24
NMRV30.80ZYT-R Series	25
NMRV40.90ZYT Series	26
NMRV50.90ZYT Series	27

2.无刷直流电机系列 Brushless Dc Motor Series

2.1无刷直流电机 Brushless Dc Motors

28BL Series	28
36BL Series	29
42BLS Series	30
42RBL Series	31
57BL Series	32
57HBL Series	33
60BLS Series	34
70BLS Series	35
80BLS Series	36
80RBL Series	37
86BLS Series	38
86RBL Series	39
110BLS Series	40

2.2无刷直行星减速电机 Brushless Dc Planetary Gear Motors

28JXE30K.28BL Series	41
36JXE30K.36BL Series	42
42JXE100K.42RBL Series	43
42JXE100K.42BLS Series	44
56JXE300K.57BL Series	45
56JXE300K.57HBL Series	46
56JXE450K.57HBL Series	47
60JXE450K.80RBL Series	48
60JXE450K.86RBL Series	49
82PN.86BL Series	50

2.3无刷直流涡轮蜗杆减速电机 Brushless Dc Worm Gear Motors

NMRV030.80BL Series	51
NMRV040.80BL Series	52
NMRV050.80BL Series	53
NMRV040.86BL Series	54
NMRV050.86BL Series	55



法拉棣
FARADY

永磁直流有刷电机30ZYT系列

Permanent Magnet Brush DC Motor 30ZYT Series

电机主要规格参数 Motor Specifications:

轴承: 高质量滚珠轴承 Bearing: High Quality Ball Bearing
 磁钢: 高性能铁氧体磁钢 2-极 Magnet: Hard Ferrite Magnet, 2- Poles
 保护等级: IP54 Protection Class: IP54
 绝缘等级: F级 / 工作温度: -40°C~+140°C
 Insulation Class: Class F / Working Temperature: -40°C~+140°C
 认证: CE 和 ROHS Certifications: CE and ROHS



可供选择 Options:

客户定制电压, 电性能, 出轴, 安装面, 引出线等。
 Customized Voltage, Winding, Shaft, Mounting, and Lead Configurations
 以及EMI/RFI 电路, 热保护, 耐高温等级
 EMI/RFI Suppression Circuit, Thermal Protection, High Temperature Class H Insulation

电机主要性能参数 Motor Main Characteristics:

型号Model	单位 Unit	30ZYT01A	30ZYT02A	30ZYT03A
额定电压 Rated Voltage	VDC	24v (可定制直流12v到48v) ; 24v (option for 12v up to 48vdc)		
额定转速 Rated Speed	Rpm	3200	3300	3000
额定转矩 Rated Torque	mN.m	10	15	30
空载转速 No Load Speed	Rpm	3800	4200	4200
重量 Weight	G	100	160	240
机身长度 Motor Length	Mm	50	60	75
额定输出功率 Output Power	W	3	5	7

图纸 Drawing

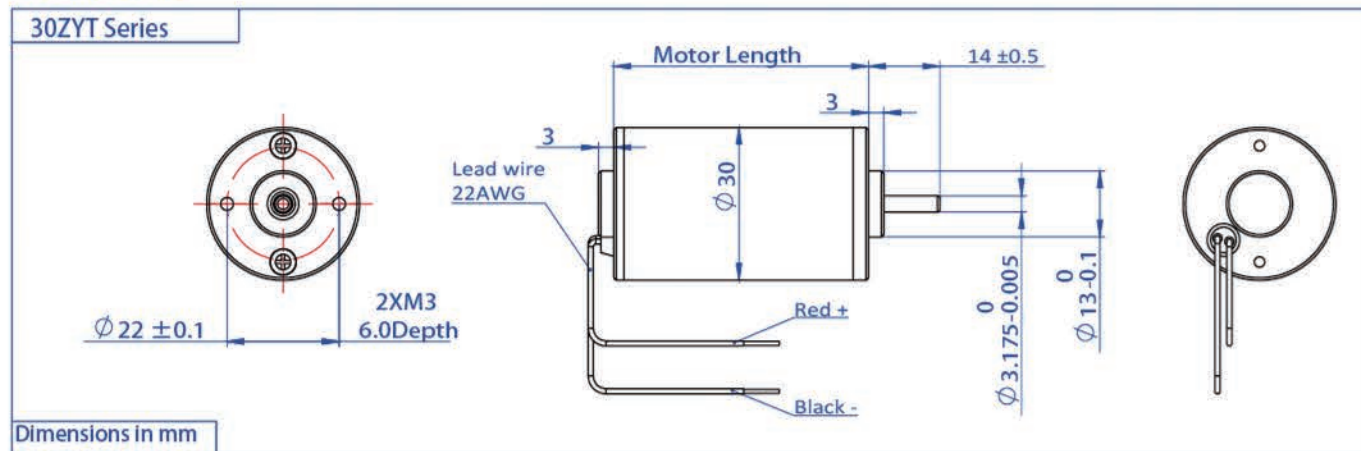

永磁直流有刷电机32ZYN(稀土磁钢)系列

Permanent Magnet Brush DC Motor 32ZYN (NdFeB Magnet) Series

电机主要规格参数 Motor Specifications:

轴承: 高质量滚珠轴承 Bearing: High Quality Ball Bearing
 磁钢: 高性能钕铁硼磁钢 2-极 Magnet: NdFeB Magnet, 2- Poles
 保护等级: IP50 Protection Class: IP50 (Option for IP54)
 绝缘等级: F级 / 工作温度: -40°C~+140°C
 Insulation Class: Class F / Working Temperature: -40°C~+140°C
 认证: CE 和 ROHS Certifications: CE and ROHS



可供选择 Options:

客户定制电压, 电性能, 出轴, 安装面, 引出线等。
 Customized Voltage, Winding, Shaft, Mounting, and Lead Configurations
 以及EMI/RFI 电路, 热保护, 耐高温等级
 EMI/RFI Suppression Circuit, Thermal Protection, High Temperature Class H Insulation

电机主要性能参数 Motor Main Characteristics:

型号Model	单位 Unit	32ZYN01A	32ZYN02A	32ZYN03A
额定电压 Rated Voltage	VDC	24v (可定制直流12v到48v) ; 24v (option for 12v up to 48vdc)		
额定转速 Rated Speed	Rpm	3000	3000	3000
额定转矩 Rated Torque	mN.m	30	40	50
空载转速 No Load Speed	Rpm	3700	3700	3700
重量 Weight	G	200	240	280
机身长度 Motor Length	Mm	60	70	80
额定输出功率 Output Power	W	9.5	12.5	16

图纸 Drawing

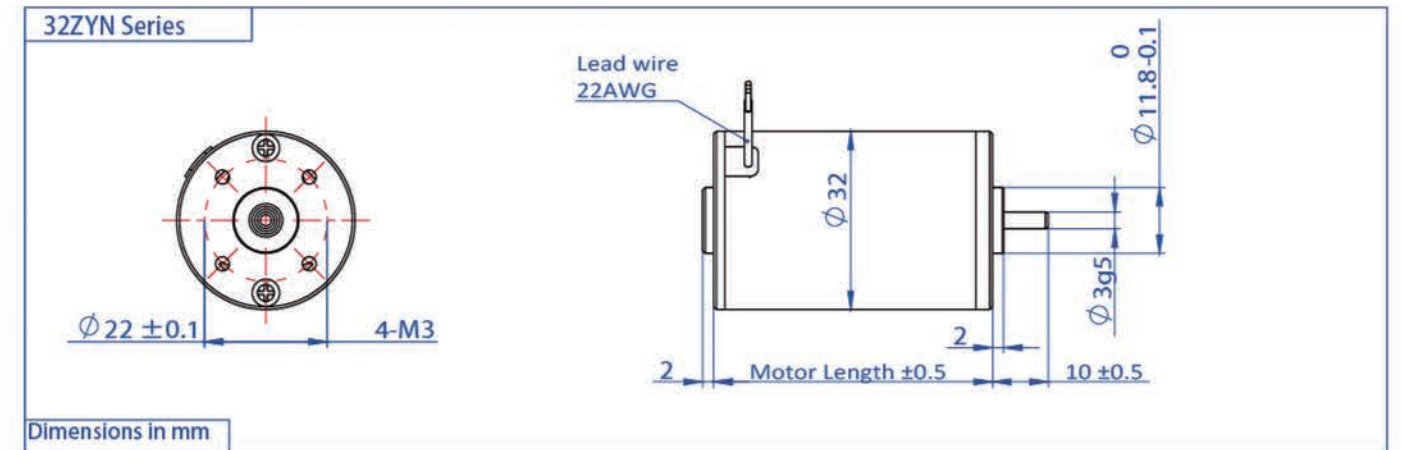

永磁直流有刷电机38ZYN(稀土磁钢)系列

Permanent Magnet Brush DC Motor 38ZYN (NdFeB Magnet) Series

电机主要规格参数 Motor Specifications:

轴承: 高质量滚珠轴承 Bearing: High Quality Ball Bearing
 磁钢: 高性能钕铁硼磁钢 2-极 Magnet: NdFeB Magnet, 2- Poles
 保护等级: IP50 Protection Class: IP50 (Option for IP54)
 绝缘等级: F级 / 工作温度: -40℃~+140℃
 Insulation Class: Class F / Working Temperature: -40℃~+140℃
 认证: CE 和 ROHS Certifications: CE and ROHS



可供选择 Options:

客户定制电压, 电性能, 出轴, 安装面, 引出线等。
 Customized Voltage, Winding, Shaft, Mounting, and Lead Configurations
 以及EMI/RFI 电路, 热保护, 耐高温等级
 EMI/RFI Suppression Circuit, Thermal Protection, High Temperature Class H Insulation

电机主要性能参数 Motor Main Characteristics:

型号Model	单位 Unit	38ZYN01A	38ZYN02A	38ZYN03A	38ZYN03B	38ZYN04A
额定电压 Rated Voltage	VDC	24v (可定制直流12V到60V) ; 24v (option for 12v up to 60vdc)				
额定转速 Rated Speed	Rpm	3300	3250	3150	8500	3200
额定力矩 Rated Torque	mN.m	55	70	100	150	100
空载转速 No Load Speed	Rpm	4000	3950	3950	9700	10000
重量 Weight	G	260	300	350	350	390
机身长度 Motor Length	Mm	60	70	80	80	90
额定输出功率 Output Power	W	19	24	33	134	40

图纸 Drawing

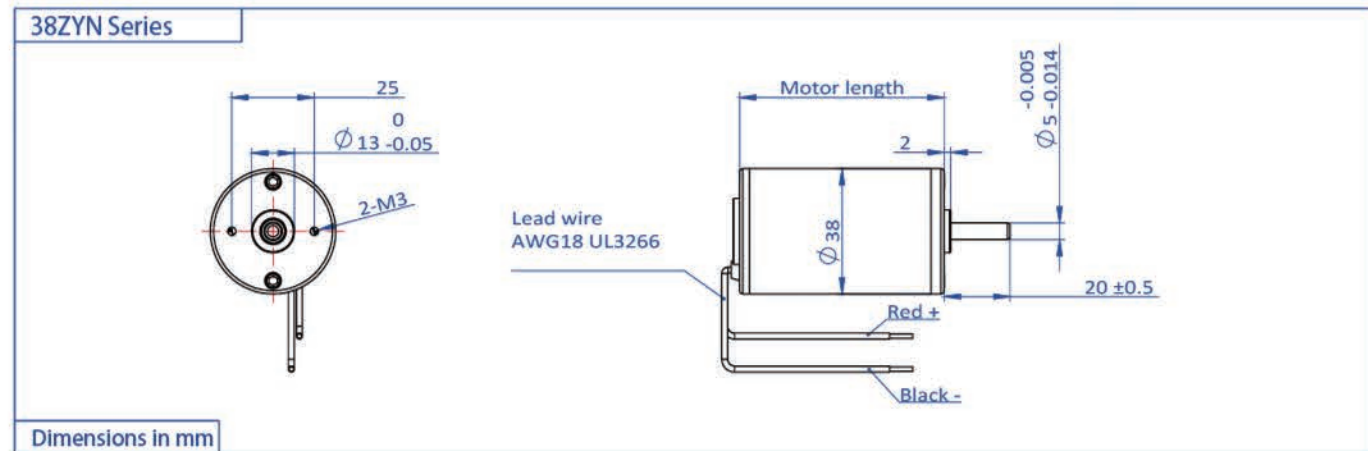

永磁直流有刷电机42ZYT 系列

Permanent Magnet Brush DC Motor 42ZYT Series

电机主要规格参数 Motor Specifications:

轴承: 高质量滚珠轴承 Bearing: High Quality Ball Bearing
 磁钢: 高性能铁氧体磁钢 2-极 Magnet: Hard Ferrite Magnet, 2- Poles
 保护等级: IP50 Protection Class: IP50
 绝缘等级: F级 / 工作温度: -40℃~+140℃
 Insulation Class: Class F / Working Temperature: -40℃~+140℃
 认证: CE 和 ROHS Certifications: CE and ROHS



可供选择 Options:

客户定制电压, 电性能, 出轴, 安装面, 引出线等。
 Customized Voltage, Winding, Shaft, Mounting, and Lead Configurations
 以及EMI/RFI 电路, 热保护, 耐高温等级
 EMI/RFI Suppression Circuit, Thermal Protection, High Temperature Class H Insulation

电机主要性能参数 Motor Main Characteristics:

型号Model	单位 Unit	42ZYT01A	42ZYT02A	42ZYT03A	42ZYT04A	42ZYT04B	42ZYT04C
额定电压 Rated Voltage	VDC	24v (可定制直流12v到60v) ; 24v (option for 12v up to 60vdc)					
额定转速 Rated Speed	Rpm	3500	3100	3300	3350	4700	8770
额定力矩 Rated Torque	mN.m	38	57	65	70	100	100
空载转速 No Load Speed	Rpm	4200	3800	4200	4000	5900	10000
重量 Weight	G	390	490	520	550	550	550
机身长度 Motor Length	Mm	70	80	85	90	90	90
额定输出功率 Output Power	W	14	19	22	25	49	92

图纸 Drawing

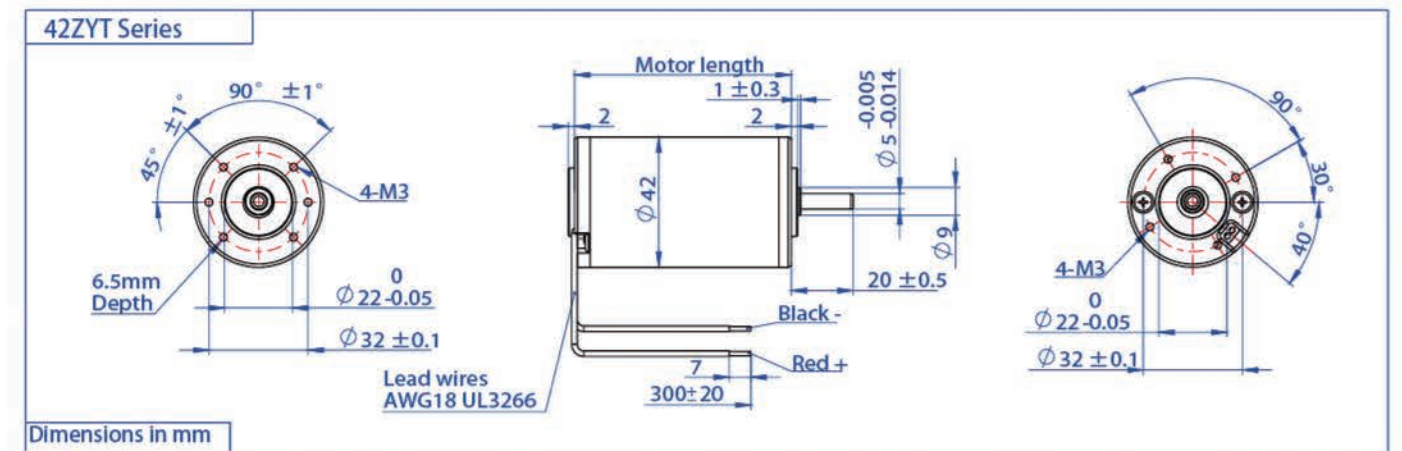

永磁直流有刷电机52ZYT 系列

Permanent Magnet Brush DC Motor 52ZYT Series

电机主要规格参数 Motor Specifications:

轴承: 高质量滚珠轴承 Bearing: High Quality Ball Bearing
 磁钢: 高性能铁氧体磁钢 2-极 Magnet: Hard Ferrite Magnet, 2- Poles
 保护等级: IP50(可选IP54) Protection Class: IP50 (Option for IP54)
 绝缘等级: F级 / 工作温度:-40℃~+140℃
 Insulation Class: Class F / Working Temperature: -40℃~+140℃
 认证: CE 和 ROHS Certifications: CE and ROHS

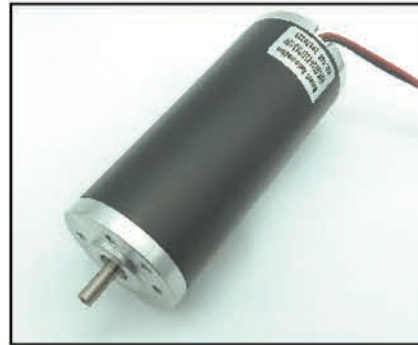

可供选择 Options:

客户定制电压, 电性能, 出轴, 安装面, 引出线等。
 Customized Voltage, Winding, Shaft, Mounting, and Lead Configurations
 以及EMI/RFI 电路, 热保护, 耐高温等级
 EMI/RFI Suppression Circuit, Thermal Protection, High Temperature Class H Insulation

电机主要性能参数 Motor Main Characteristics:

型号Model	单位 Unit	52ZYT01A	52ZYT02A	52ZYT02B	52ZYT03A	52ZYT03B
额定电压 Rated Voltage	VDC	24v (可定制直流12v到60v) ; 24v (option for 12v up to 60vdc)				
额定转速 Rated Speed	Rpm	3700	3500	9736	3300	4200
额定力矩 Rated Torque	N.m	0.11	0.20	0.20	0.27	0.27
空载转速 No Load Speed	Rpm	4200	4200	10652	4000	4200
重量 Weight	Kg	0.85	0.98	0.98	1.16	1.16
机身长度 Motor Length	Mm	95	110	110	125	125
额定输出功率 Output Power	W	43	73	204	93	154

图纸 Drawing

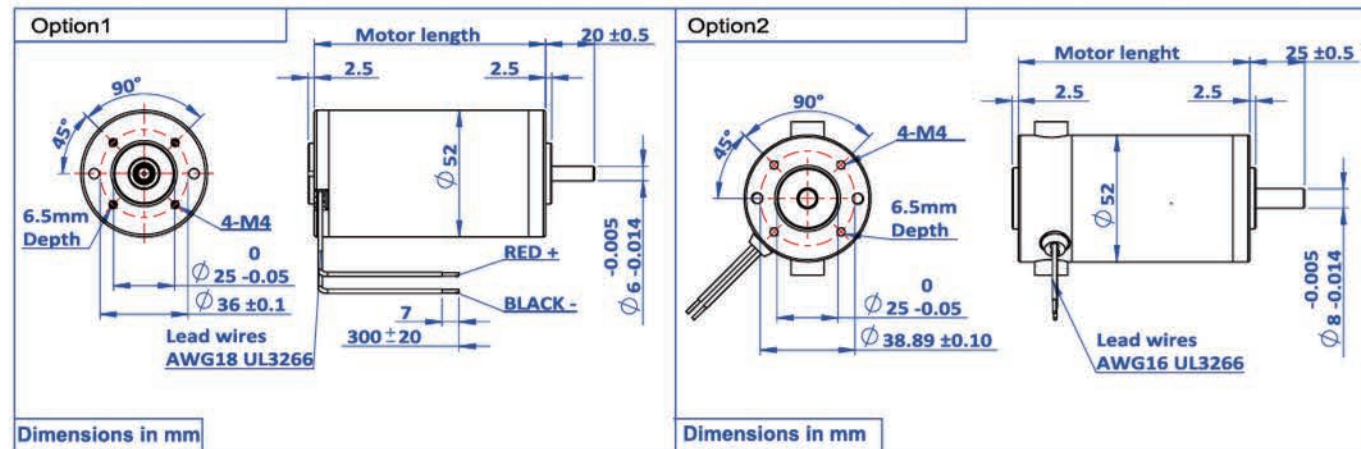

永磁直流有刷电机52ZYT-高转速可更换碳刷 系列

Permanent Magnet Brush DC Motor 52ZYT-High Speed Series

电机主要规格参数 Motor Specifications:

轴承: 高质量滚珠轴承 Bearing: High Quality Ball Bearing
 磁钢: 高性能铁氧体磁钢 2-极 Magnet: Hard Ferrite Magnet, 2- Poles
 保护等级: IP50 Protection Class: IP50
 绝缘等级: F级 / 工作温度:-40℃~+140℃
 Insulation Class: Class F / Working Temperature: -40℃~+140℃
 认证: CE 和 ROHS Certifications: CE and ROHS



可供选择 Options:

客户定制电压, 电性能, 出轴, 安装面, 引出线等。
 Customized Voltage, Winding, Shaft, Mounting, and Lead Configurations
 以及EMI/RFI 电路, 热保护, 耐高温等级
 EMI/RFI Suppression Circuit, Thermal Protection, High Temperature Class H Insulation

电机主要性能参数 Motor Main Characteristics:

型号Model	单位 Unit	52ZYT-R110	52ZYT-R117	52ZYT-R125
额定电压 Rated Voltage	VDC	24v (可定制直流12v到120v) ; 24v (option for 12v up to 120vdc)		
额定转速 Rated Speed	Rpm	11000	11000	11000
额定力矩 Rated Torque	N.m	0.25	0.28	0.3
空载转速 No Load Speed	Rpm	12000	12000	12000
重量 Weight	Kg	0.85	0.9	1.0
机身长度 Motor Length	Mm	110	117	125
额定输出功率 Output Power	W	288	323	346

图纸 Drawing

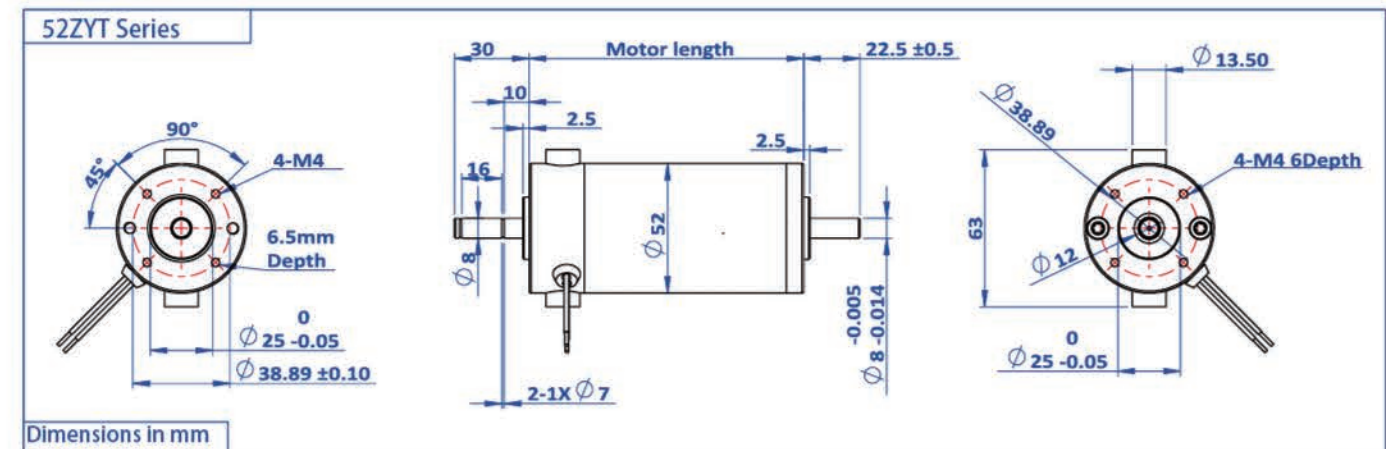

永磁直流有刷电机76ZYT 系列

Permanent Magnet Brush DC Motor 76ZYT Series

电机主要规格参数 Motor Specifications:

轴承: 高质量滚珠轴承 Bearing: High Quality Ball Bearing
 磁钢: 高性能铁氧体磁钢 2-极 Magnet: Hard Ferrite Magnet, 2- Poles
 保护等级: IP54(可选IP65) Protection Class: IP54 (Option for IP65)
 绝缘等级: F级 / 工作温度:-40℃~+140℃
 Insulation Class: Class F / Working Temperature: -40℃~+140℃
 认证: CE 和 ROHS Certifications: CE and ROHS

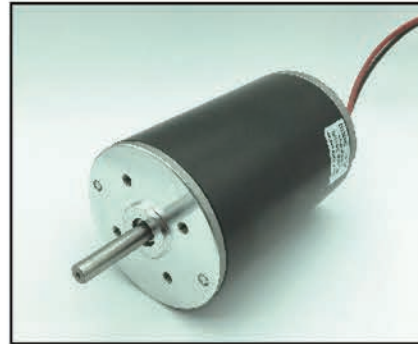

可供选择 Options:

客户定制电压, 电性能, 出轴, 安装面, 引出线等。
 Customized Voltage, Winding, Shaft, Mounting, and Lead Configurations
 以及EMI/RFI 电路, 热保护, 耐高温等级
 EMI/RFI Suppression Circuit, Thermal Protection, High Temperature Class H Insulation

电机主要性能参数 Motor Main Characteristics:

型号Model	单位 Unit	76ZYT01A	76ZYT02A	76ZYT02B	76ZYT02C	76ZYT03A	76ZYT04A	76ZYT05A
额定电压 Rated Voltage	VDC	24v (可定制直流12v到120v); 24v (option for 12v up to 120vdc)						
额定转速 Rated Speed	Rpm	3300	3200	4000	7500	3200	3150	3150
额定力矩 Rated Torque	N.m	0.31	0.4	0.4	0.5	0.6	0.8	0.8
空载转速 No Load Speed	Rpm	4000	3800	4500	8200	3800	3700	3700
重量 Weight	Kg	1.5	2.0	2.0	2.0	2.5	2.85	3.0
机身长度 Motor Length	Mm	98	118	118	118	138	150	160
额定输出功率 Output Power	W	105	151	168	393	201	231	264

图纸 Drawing

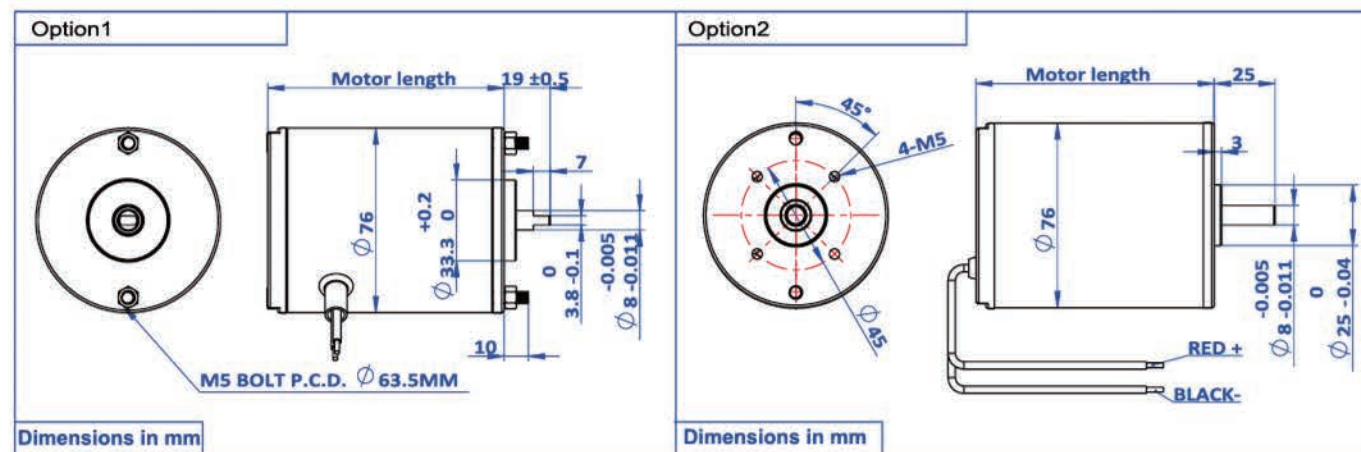

永磁直流有刷电机80ZYT 系列

Permanent Magnet Brush DC Motor 80ZYT Series

电机主要规格参数 Motor Specifications:

轴承: 高质量滚珠轴承 Bearing: High Quality Ball Bearing
 磁钢: 高性能铁氧体磁钢 2-极 Magnet: Hard Ferrite Magnet, 2- Poles
 保护等级: IP50(可选IP54) Protection Class: IP50 (Option for IP54)
 绝缘等级: F级 / 工作温度:-40℃~+140℃
 Insulation Class: Class F / Working Temperature: -40℃~+140℃
 认证: CE 和 ROHS Certifications: CE and ROHS

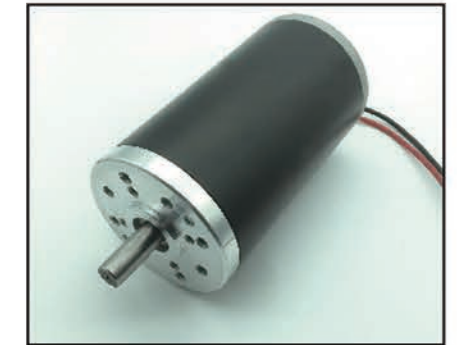

可供选择 Options:

客户定制电压, 电性能, 出轴, 安装面, 引出线等。
 Customized Voltage, Winding, Shaft, Mounting, and Lead Configurations
 以及EMI/RFI 电路, 热保护, 耐高温等级
 EMI/RFI Suppression Circuit, Thermal Protection, High Temperature Class H Insulation

电机主要性能参数 Motor Main Characteristics:

型号Model	单位 Unit	80ZYT01A	80ZYT02A	80ZYT03A
额定电压 Rated Voltage	VDC	24v (可定制直流12v到230v); 24v (option for 12v up to 230vdc)		
额定转速 Rated Speed	Rpm	2900	2900	3000
额定力矩 Rated Torque	N.m	0.6	0.8	1.0
空载转速 No Load Speed	Rpm	3600	3600	3600
重量 Weight	Kg	2.8	3.2	3.7
机身长度 Motor Length	Mm	120	140	160
额定输出功率 Output Power	W	182	243	314

图纸 Drawing

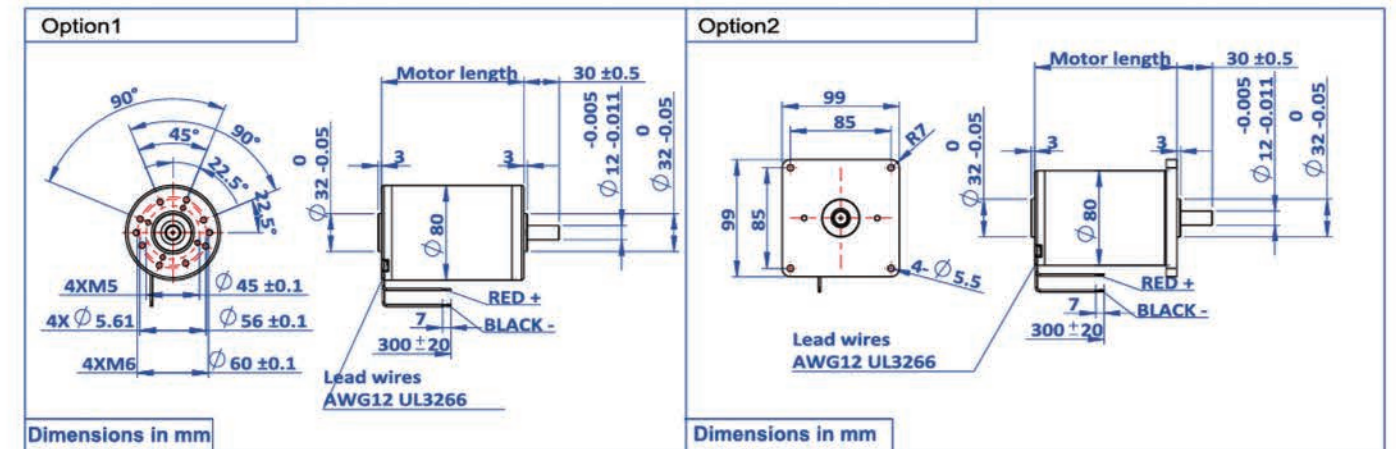

永磁直流有刷电机80ZYT-R可更换碳刷系列 (大碳刷 长寿命)

Permanent Magnet Brush DC Motor 80ZYT-R Replaceable Brushes Series

电机主要规格参数 Motor Specifications:

轴承: 高质量滚珠轴承 Bearing: High quality ball bearing
 磁钢: 高性能磁钢 2-极 Magnet: Hard ferrite magnet, 2- poles
 保护等级: IP50 Protection Class: IP50
 绝缘等级: F级 / 工作温度: -40°C~+140°C
 Insulation class: Class F / Working Temperature: -40°C~+140°C
 认证: CE 和 ROHS Certifications: CE and ROHS

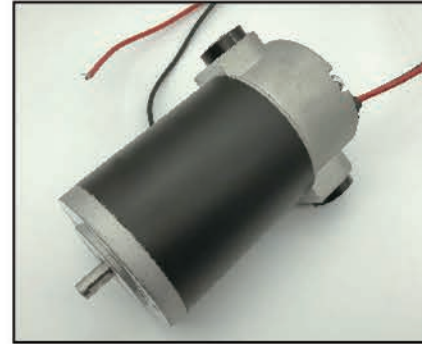

可供选择 Options:

客户定制电压, 电性能, 出轴, 安装面, 引出线等。
 Customized voltage, winding, shaft, mounting, and lead configurations
 以及EMI/RFI 电路, 热保护, 耐高温等级
 EMI/RFI suppression circuit; Thermal protection, high temperature Class H insulation

电机主要性能参数 Motor Main Characteristics:

型号Model	单位 Unit	80ZYT-R01	80ZYT-R02	80ZYT-R03
额定电压 Rated Voltage	VDC	24v (可定制直流12v到120v) ; 24v (option for 12v up to 120v)		
额定转速 Rated Speed	Rpm	2600	2600	3000
额定力矩 Rated Torque	N.m	0.45	0.65	0.85
空载转速 No Load Speed	Rpm	2900	2900	2900
重量 Weight	Kg	3.0	3.2	3.4
机身长度 Motor Length	Mm	140	160	180
额定输出功率 Output Power	W	122	177	231

图纸 Drawing

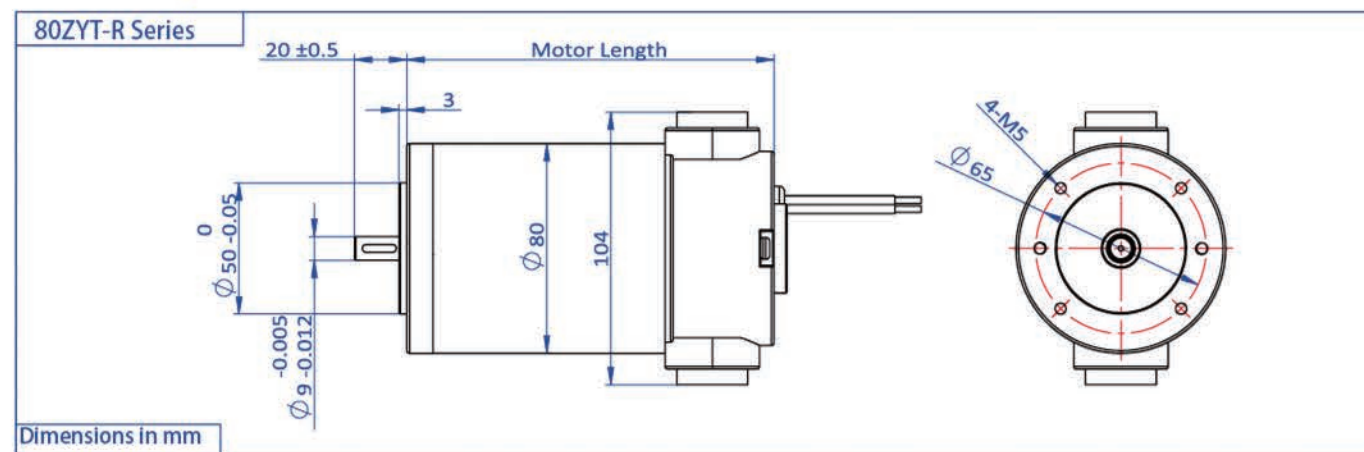

永磁直流有刷电机90ZYT 系列

Permanent Magnet Brush DC Motor 90ZYT Series

电机主要规格参数 Motor Specifications:

轴承: 高质量滚珠轴承 Bearing: High Quality Ball Bearing
 磁钢: 高性能铁氧体磁钢 4-极 Magnet: Hard Ferrite Magnet, 4- Poles
 保护等级: IP50(可选IP54) Protection Class: IP50 (Option for IP54)
 绝缘等级: F级 / 工作温度: -40°C~+140°C
 Insulation Class: Class F / Working Temperature: -40°C~+140°C
 认证: CE 和 ROHS Certifications: CE and ROHS

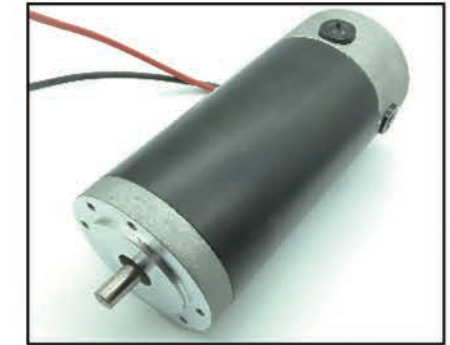

可供选择 Options:

客户定制电压, 电性能, 出轴, 安装面, 引出线等。
 Customized Voltage, Winding, Shaft, Mounting, and Lead Configurations
 以及EMI/RFI 电路, 热保护, 耐高温等级
 EMI/RFI Suppression Circuit, Thermal Protection, High Temperature Class H Insulation

电机主要性能参数 Motor Main Characteristics:

型号Model	单位 Unit	90ZYT01A	90ZYT-180	90ZYT02A
额定电压 Rated Voltage	VDC	24v (可定制直流12v到230v) ; 24v (option for 12v up to 230vdc)		
额定转速 Rated Speed	Rpm	3000	3000	3000
额定力矩 Rated Torque	N.m	1.2	1.6	1.8
空载转速 No Load Speed	Rpm	3600	3500	3600
重量 Weight	Kg	3.5	4.0	4.5
机身长度 Motor Length	Mm	155	180	199
额定输出功率 Output Power	W	377	503	565

图纸 Drawing

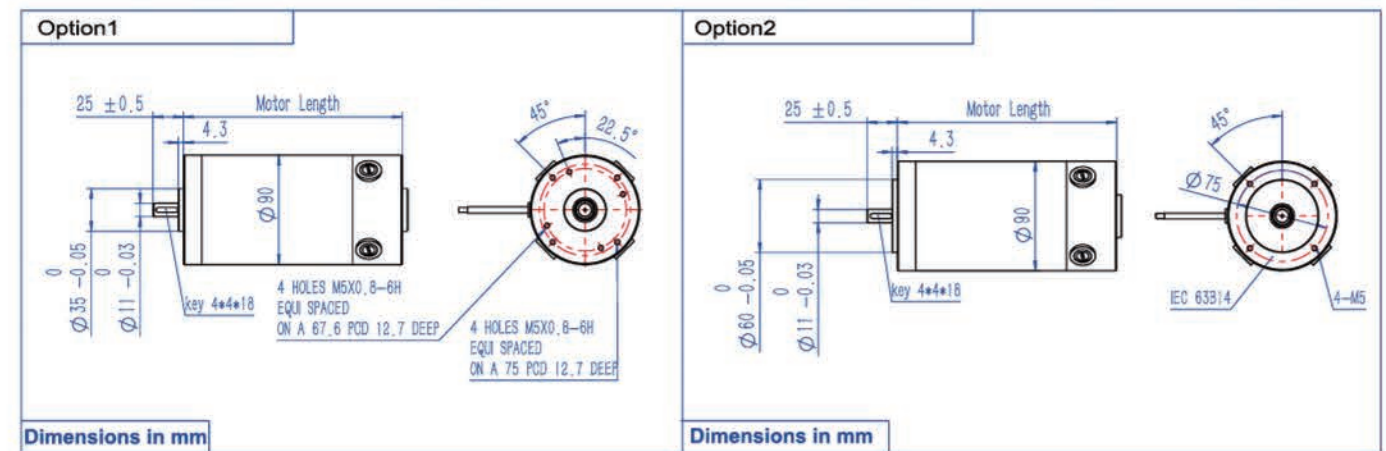

直流有刷行星减速电机36JXE30K.38ZYN 系列 (稀土磁钢电机)
Brush DC Planetary Gear Motor 36JXE30K.38ZYN Series (NdFeB Magnet Motor)

电机主要规格参数 Motor Specifications:

轴承: 高质量滚珠轴承 Bearing: High Quality Ball Bearing
磁钢: 高性能钕铁硼磁钢 2-极 Magnet: NdFeB Magnet, 2- Poles
保护等级: IP50 Protection Class: IP50 (Option for IP54)
绝缘等级: F级 / 工作温度: -40℃~+140℃
Insulation Class: Class F / Working Temperature: -40℃~+140℃
认证: CE 和 ROHS Certifications: CE and ROHS



电机主要性能参数 Motor Main Characteristics:

型号Model	单位 Unit	38ZYN01A	38ZYN02A	38ZYN03A	38ZYN03B	38ZYN04A
额定电压 Rated Voltage	VDC	24v (可定制直流12V到60V); 24v (option for 12v up to 60vdc)				
额定转速 Rated Speed	Rpm	3300	3250	3150	8500	3200
额定力矩 Rated Torque	mN.m	55	70	100	150	120
空载转速 No Load Speed	Rpm	4000	3950	3950	9700	4000
重量 Weight	G	260	300	350	350	390
机身长度 Motor Length	Mm	60	70	80	80	90
额定输出功率 Output Power	W	19	24	33	134	40

行星齿轮箱主要性能参数 Planetary Gearbox Specifications:型号 Gearbox Model: 36JXE30K

内齿圈材料 Ring material	E 型:金属 Metal
输出轴轴承形式 Bearing at output	滚动轴承Ball bearings
最大允许径向负载(离法兰10mm处) Max. Radial load (10mm from flange)	≤50N
最大允许轴向负载Max. shaft axial load	≤30N
径向间隙 (测量点尽量接近法兰) Radial play of shaft (near to flange)	≤0.07mm
轴向间隙 Axial play of shaft	≤0.3mm
背隙 (无负载时) Backlash at no-load	≤2.5°
输出轴最大承受压入力 Shaft press fit force max	≤120N

减速比 Reduction ratio	额定允许负载 Rated tolerance torque	瞬间允许负载 Max momentary tolerance torque	效率 Efficiency	L (mm)	重量 (g) Weight(g)
1/3.7 1/5.2	0.3N.m	1.0N.m	90%	26.5±0.5	168
1/14 1/19 1/27	1.2N.m	3.5N.m	81%	33.6±0.5	207
1/51 1/71 1/100 1/139	2.5N.m	7.5N.m	73%	40.5±0.5	248
1/182 1/219 1/254 1/306 1/354 1/427 1/495 1/596	3.0N.m	9.0N.m	66%	47.4±0.5	296

图纸 Drawing

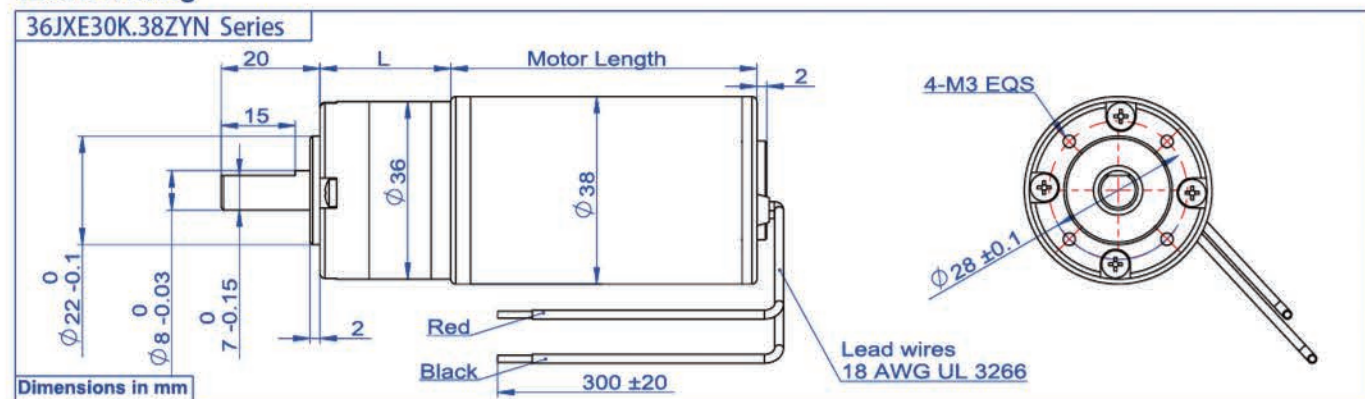

直流有刷行星减速电机42JXE100K.42ZYT 系列
Brush DC Planetary Gear Motor 42JXE100K.42ZYT Series

电机主要规格参数 Motor Specifications:

轴承: 高质量滚珠轴承 Bearing: High Quality Ball Bearing
磁钢: 高性能铁氧体磁钢 2-极 Magnet: Hard Ferrite Magnet, 2- Poles
保护等级: IP50 Protection Class: IP50
绝缘等级: F级 / 工作温度: -40℃~+140℃
Insulation Class: Class F / Working Temperature: -40℃~+140℃
认证: CE 和 ROHS Certifications: CE and ROHS



电机主要性能参数 Motor Main Characteristics:

型号Model	单位 Unit	42ZYT01A	42ZYT02A	42ZYT03A	42ZYT04A	42ZYT04B	42ZYT04C
额定电压 Rated Voltage	VDC	24v (可定制直流12v到60v); 24v (option for 12v up to 60vdc)					
额定转速 Rated Speed	Rpm	3500	3100	3300	3350	4700	8770
额定力矩 Rated Torque	mN.m	38	57	65	70	100	100
空载转速 No Load Speed	Rpm	4200	3800	4200	4000	5900	10000
重量 Weight	G	390	490	520	550	550	550
机身长度 Motor Length	Mm	70	80	85	90	90	90
额定输出功率 Output Power	W	14	19	22	25	49	92

行星齿轮箱主要性能参数 Planetary Gearbox Specifications:型号 Gearbox Model: 42JXE100K

内齿圈材料 Ring material	E 型:金属 Metal
输出轴轴承形式 Bearing at output	滚动轴承Ball bearings
最大允许径向负载(离法兰10mm处) Max. Radial load (10mm from flange)	≤80N
最大允许轴向负载Max. shaft axial load	≤30N
径向间隙 (测量点尽量接近法兰) Radial play of shaft (near to flange)	≤0.06mm
轴向间隙 Axial play of shaft	≤0.3mm
背隙 (无负载时) Backlash at no-load	≤2.5°
输出轴最大承受压入力 Shaft press fit force, max	≤150N

减速比 Reduction ratio	额定允许负载 Rated tolerance torque	瞬间允许负载 Max momentary tolerance torque	效率 Efficiency	L (mm)	重量 (g) Weight(g)
1/3.7 1/5.2	1.0N.m	3.0N.m	90%	31.5±0.5	244
1/14 1/19 1/27	4.0N.m	12N.m	81%	42.1±0.5	314
1/51 1/71 1/100 1/139	8.0N.m	25N.m	73%	52.5±0.5	433
1/182 1/219 1/254 1/306 1/354 1/427 1/495 1/596	10N.m	30N.m	66%	62.9±0.5	519

图纸 Drawing

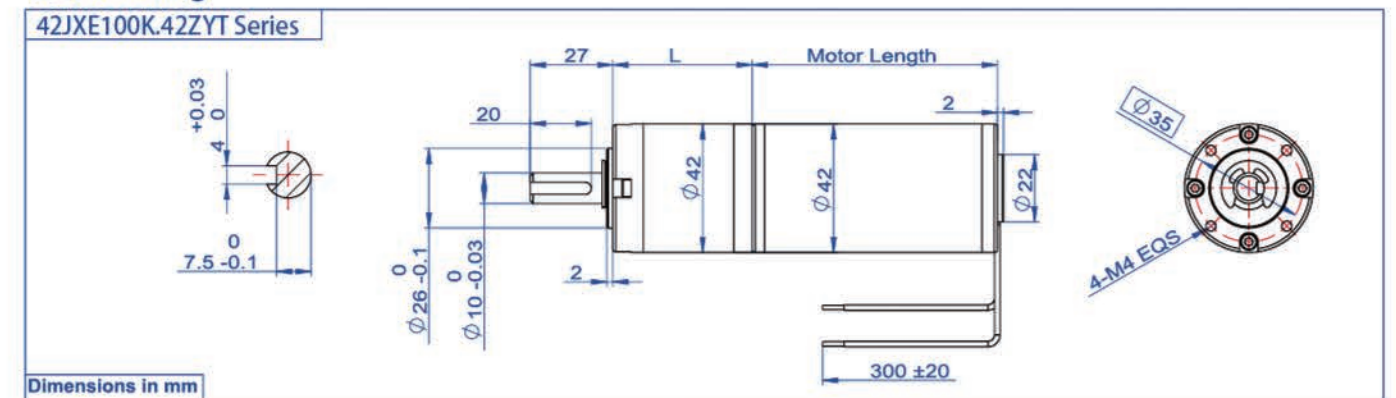

直流有刷行星减速电机42JXGT200K.42ZYT 系列 (超大力矩系列)

Brush DC Planetary Gear Motor 42JXGT200K.42ZYT Series (Large Torque Version)

电机主要规格参数 Motor Specifications:

轴承: 高质量滚珠轴承 Bearing: High Quality Ball Bearing
 磁钢: 高性能铁氧体磁钢 2-极 Magnet: Hard Ferrite Magnet, 2- Poles
 保护等级: IP50 Protection Class: IP50
 绝缘等级: F级 / 工作温度: -40℃~+140℃
 Insulation Class: Class F / Working Temperature: -40℃~+140℃
 认证: CE 和 ROHS Certifications: CE and ROHS



电机主要性能参数 Motor Main Characteristics:

型号Model	单位 Unit	42ZYT01A	42ZYT02A	42ZYT03A	42ZYT04A	42ZYT04B	42ZYT04C
额定电压 Rated Voltage	VDC	24v (可定制直流12v到60v) ; 24v (option for 12v up to 60vdc)					
额定转速 Rated Speed	Rpm	3500	3100	3300	3350	4700	8770
额定力矩 Rated Torque	mN.m	38	57	65	70	100	100
空载转速 No Load Speed	Rpm	4200	3800	4200	4000	5900	10000
重量 Weight	G	390	490	520	550	550	550
机身长度 Motor Length	Mm	70	80	85	90	90	90
额定输出功率 Output Power	W	14	19	22	25	49	92

行星齿轮箱主要性能参数 Planetary Gearbox Specifications:型号 Gearbox Model: 42JXGT200K

内齿圈材料 Ring material	E 型:金属 Metal
输出轴轴承形式 Bearing at output	滚动轴承Ball bearings
最大允许径向负载(离法兰10mm处) Max. Radial load (10mm from flange)	≤80N
最大允许轴向负载Max. shaft axial load	≤30N
径向间隙 (测量点尽量接近法兰) Radial play of shaft (near to flange)	≤0.06mm
轴向间隙 Axial play of shaft	≤0.3mm
背隙 (无负载时) Backlash at no-load	≤2.5°
输出轴最大承受压入力 Shaft press fit force max	≤150N

减速比 Reduction ratio	额定允许负载 Rated tolerance torque	瞬间允许负载 Max momentary tolerance torque	效率 Efficiency	L (mm)	重量 (g) Weight(g)
1/4.44	2.0N.m	6.0N.m	90%	39.8±0.5	244
1/17 1/22	8.0N.m	25N.m	81%	50.4±0.5	323
1/65 1/83 1/106	16N.m	50N.m	73%	60.8±0.5	380
1/247 1/316 1/403 1/515	20N.m	60N.m	66%	71.2±0.5	468
1/944 1/1206 1/1540 1/1966 1/2510	20N.m	60N.m	59%	81.6±0.5	548

图纸 Drawing

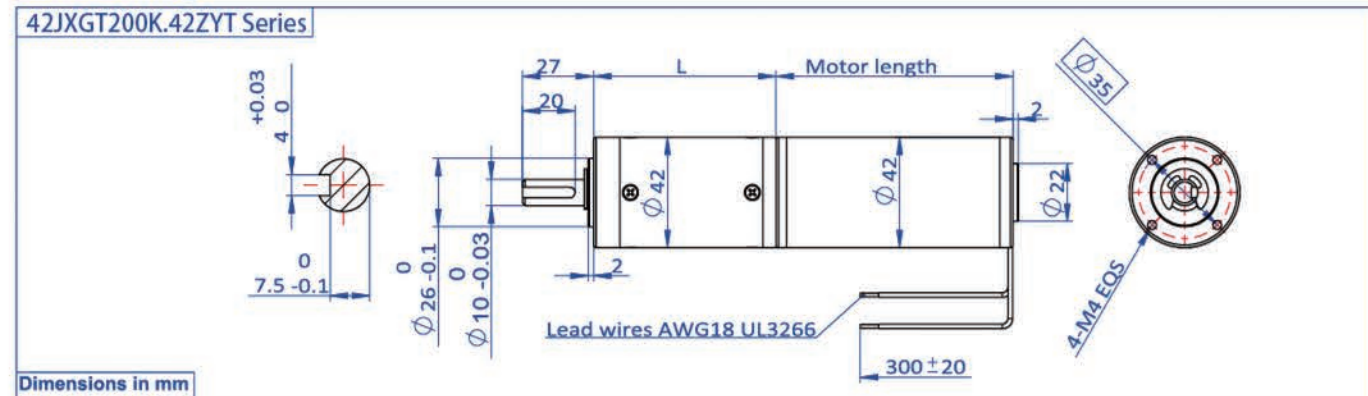

直流有刷行星减速电机52JXE300K.52ZYT 系列

Brush DC Planetary Gear Motor 52JXE300K.52ZYT Series

电机主要规格参数 Motor Specifications:

轴承: 高质量滚珠轴承 Bearing: High Quality Ball Bearing
 磁钢: 高性能铁氧体磁钢 2-极 Magnet: Hard Ferrite Magnet, 2- Poles
 保护等级: IP50(可选IP54) Protection Class: IP50 (Option for IP54)
 绝缘等级: F级 / 工作温度: -40℃~+140℃
 Insulation Class: Class F / Working Temperature: -40℃~+140℃
 认证: CE 和 ROHS Certifications: CE and ROHS



电机主要性能参数 Motor Main Characteristics:

型号Model	单位 Unit	52ZYT01A	52ZYT02A	52ZYT02B	52ZYT03A	52ZYT03B
额定电压 Rated Voltage	VDC	24v (可定制直流12v到60v) ; 24v (option for 12v up to 60vdc)				
额定转速 Rated Speed	Rpm	3700	3500	9736	3300	4200
额定力矩 Rated Torque	N.m	0.11	0.20	0.20	0.27	0.35
空载转速 No Load Speed	Rpm	4200	4200	10652	4000	5200
重量 Weight	Kg	0.85	0.98	0.98	1.16	1.16
机身长度 Motor Length	Mm	95	110	110	125	125
额定输出功率 Output Power	W	43	73	204	93	154

行星齿轮箱主要性能参数 Planetary Gearbox Specifications:

内齿圈材料 Ring material	E 型:金属 Metal
输出轴轴承形式 Bearing at output	滚动轴承Ball bearings
最大允许径向负载(离法兰10mm处) Max. Radial load (10mm from flange)	≤250N
最大允许轴向负载Max. shaft axial load	≤100N
径向间隙 (测量点尽量接近法兰) Radial play of shaft (near to flange)	≤0.08mm
轴向间隙 Axial play of shaft	≤0.4mm
背隙 (无负载时) Backlash at no-load	≤2.5°
输出轴最大承受压入力 Shaft press fit force max	≤300N

减速比 Reduction ratio	额定允许负载 Rated tolerance torque	瞬间允许负载 Max momentary tolerance torque	效率 Efficiency	L (mm)	重量 (g) Weight(g)
1/3.6 1/4.3	2.0N.m	6.0N.m	90%	45.7±0.5	442
1/13 1/15 1/18	8.0N.m	25N.m	81%	57.2±0.5	574
1/47 1/55 1/65 1/77	16.0N.m	50N.m	73%	68.5±0.5	702
1/168 1/198 1/234 1/276 1/326	20N.m	60N.m	66%	79.8±0.5	837

图纸 Drawing

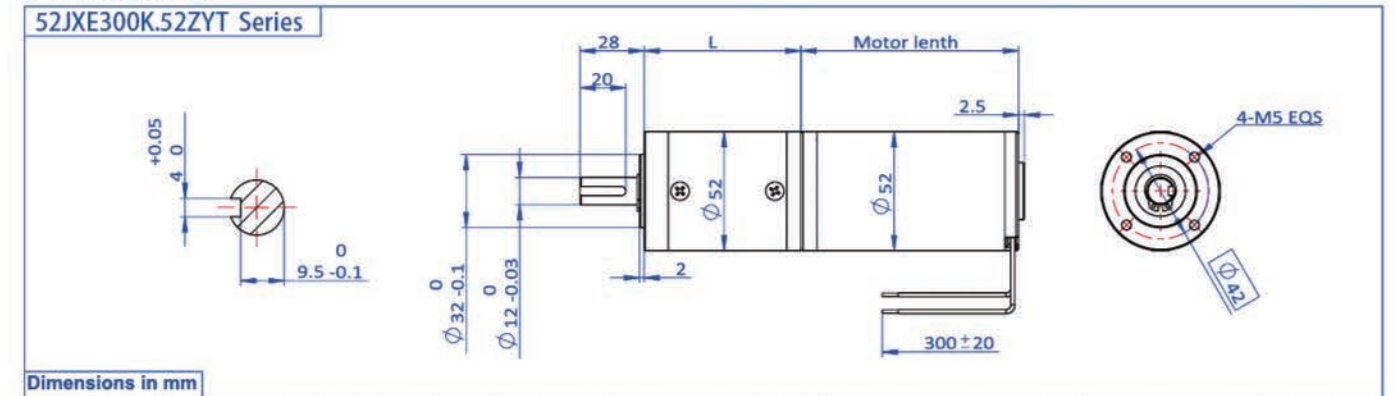

直流有刷行星减速电机56(60)JXE300K.63ZYT 系列
Brush DC Planetary Gear Motor 56(60)JXE300K.63ZYT Series



电机主要规格参数 Motor Specifications:

轴承: 高质量滚珠轴承 Bearing: High Quality Ball Bearing
磁钢: 高性能铁氧体磁钢 2-极 Magnet: Hard Ferrite Magnet, 2- Poles
保护等级: IP50(可选IP54) Protection Class: IP50 (Option for IP54)
绝缘等级: F级 / 工作温度:-40℃~+140℃
Insulation Class: Class F / Working Temperature: -40℃~+140℃
认证: CE 和 ROHS Certifications: CE and ROHS

电机主要性能参数 Motor Main Characteristics:

型号Model	单位Unit	63ZYT01A	63ZYT01B	63ZYT01C	63ZYT02A	63ZYT02B	63ZYT02C	63ZYT03A	63ZYT03B	63ZYT04A	
额定电压 Rated Voltage	VDC	24v (可定制直流12v到120v); 24v (option for 12v up to 120vdc)									
额定转速 Rated Speed	Rpm	3300	4000	9500	3000	4000	7500	3000	4000	3000	
额定力矩 Rated Torque	N.m	0.15	0.2	0.2	0.31	0.35	0.4	0.4	0.4	0.5	
空载转速 No Load Speed	Rpm	3600	4700	10000	3500	4700	8400	3500	4700	3600	
重量 Weight	Kg	1.0	1.0	1.0	1.2	1.2	1.2	1.35	1.35	1.50	
机身长度 Motor Length	Mm	95	95	95	110	110	110	125	125	140	
额定输出功率 Output Power	W	52	84	200	97	147	314	126	168	157	

行星齿轮箱主要性能参数 Planetary Gearbox Specifications:型号 Gearbox Model: 56(60)JXE300K

内齿圈材料 Ring material	E 型:金属 Metal
输出轴轴承形式 Bearing at output	滚动轴承Ball bearings
最大允许径向负载(离法兰10mm处) Max. Radial load (10mm from flange)	≤250N
最大允许轴向负载Max. shaft axial load	≤100N
径向间隙 (测量点尽量接近法兰) Radial play of shaft (near to flange)	≤0.08mm
轴向间隙 Axial play of shaft	≤0.4mm
背隙 (无负载时) Backlash at no-load	≤2.5°
输出轴最大承受压入力 Shaft press fit force max	≤300N

减速比 Reduction ratio	额定允许负载 Rated tolerance torque	瞬间允许负载 Max momentary tolerance torque	效率 Efficiency	L (mm)	重量 (g) Weight(g)
1/3.6 1/4.3	3.0N.m	9.0N.m	90%	37.8±0.5	489
1/13 1/15 1/18 1/23	12.0N.m	36N.m	81%	49.5±0.5	681
1/47 1/55 1/65 1/77 1/96 1/121	24.0N.m	72N.m	73%	60.8±0.5	871
1/154 1/187 1/220 1/260 1/307 1/409 1/514 1/645	30N.m	90N.m	66%	71.9±0.5	1066

图纸 Drawing

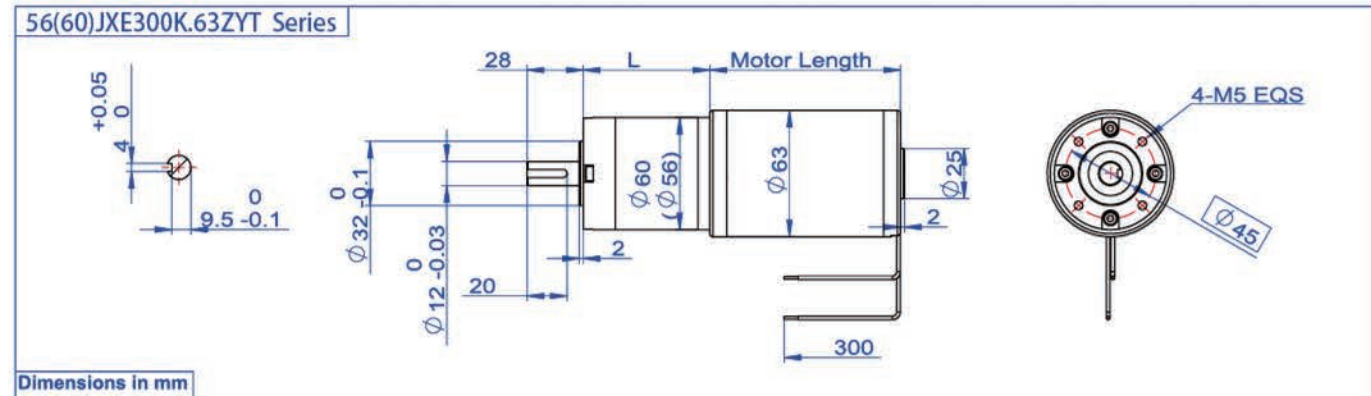

直流有刷行星减速电机60JXE450K.76ZYT 系列
Brush DC Planetary Gear Motor 60JXE450K.76ZYT Series



电机主要规格参数 Motor Specifications:

轴承: 高质量滚珠轴承 Bearing: High Quality Ball Bearing
磁钢: 高性能铁氧体磁钢 2-极 Magnet: Hard Ferrite Magnet, 2- Poles
保护等级: IP54(可选IP65) Protection Class: IP54 (Option for IP65)
绝缘等级: F级 / 工作温度:-40℃~+140℃
Insulation Class: Class F / Working Temperature: -40℃~+140℃
认证: CE 和 ROHS Certifications: CE and ROHS

电机主要性能参数 Motor Main Characteristics:

型号Model	单位 Unit	76ZYT01A	76ZYT02A	76ZYT02B	76ZYT02C	76ZYT03A	76ZYT04A	76ZYT05A	
额定电压 Rated Voltage	VDC	24v (可定制直流12v到120v); 24v (option for 12v up to 120vdc)							
额定转速 Rated Speed	Rpm	3300	3200	4000	7500	3200	3150	3150	
额定力矩 Rated Torque	N.m	0.31	0.4	0.4	0.5	0.6	0.7	0.8	
空载转速 No Load Speed	Rpm	4000	3800	4500	8200	3800	3700	3700	
重量 Weight	Kg	1.5	2.0	2.0	2.0	2.5	2.85	3.0	
机身长度 Motor Length	Mm	98	118	118	118	138	150	160	
额定输出功率 Output Power	W	105	151	168	393	201	231	264	

行星齿轮箱主要性能参数 Planetary Gearbox Specifications:型号 Gearbox Model: 60JXE450K

内齿圈材料 Ring material	E 型:金属 Metal
输出轴轴承形式 Bearing at output	滚动轴承Ball bearings
最大允许径向负载(离法兰10mm处) Max. Radial load (10mm from flange)	≤400N
最大允许轴向负载Max. shaft axial load	≤120N
径向间隙 (测量点尽量接近法兰) Radial play of shaft (near to flange)	≤0.08mm
轴向间隙 Axial play of shaft	≤0.4mm
背隙 (无负载时) Backlash at no-load	≤1.5°
输出轴最大承受压入力 Shaft press fit force, max	≤300N

减速比 Reduction ratio	额定允许负载 Rated tolerance torque	瞬间允许负载 Max momentary tolerance torque	效率 Efficiency	L (mm)	重量 (g) Weight(g)
1/3.6 1/4.25 1/5.33	4 N.m	12 N.m	90%	40.3±0.5	520
1/13 1/15 1/18 1/23 1/28	18 N.m	36 N.m	81%	53.8±0.5	710
1/43 1/52 1/61 1/72 1/96 1/121	36 N.m	72 N.m	73%	67.2±0.5	900
1/154 1/187 1/220 1/260 1/307 1/409 1/514 1/645 1/809	45 N.m	90N.m	66%	80.6±0.5	1100

图纸 Drawing

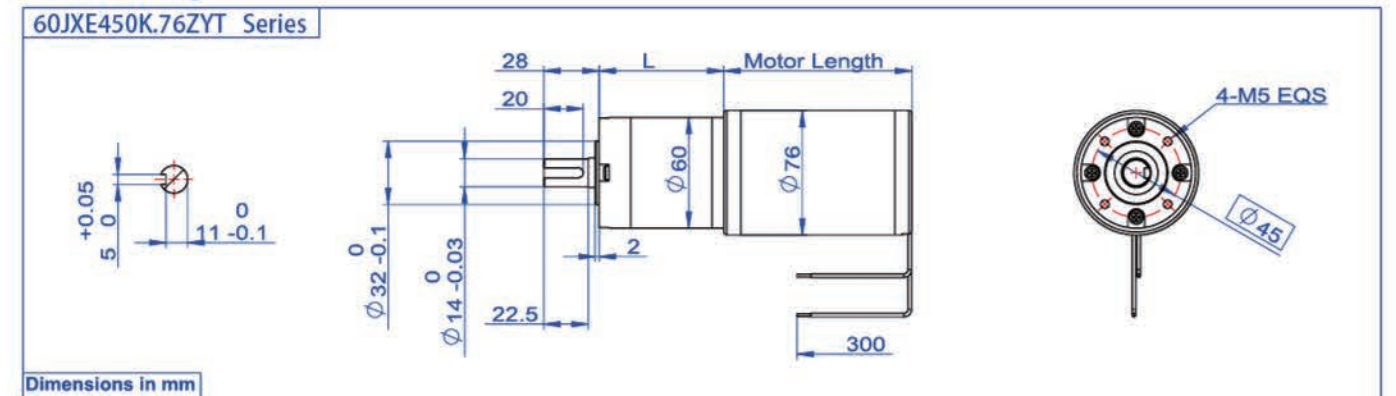

直流有刷行星减速电机60JXE450K.80ZYT 系列
Brush DC Planetary Gear Motor 60JXE450K.80ZYT Series



电机主要规格参数 Motor Specifications:

轴承: 高质量滚珠轴承 Bearing: High Quality Ball Bearing
磁钢: 高性能铁氧体磁钢 2-极 Magnet: Hard Ferrite Magnet, 2- Poles
保护等级: IP50(可选IP54) Protection Class: IP50 (Option for IP54)
绝缘等级: F级 / 工作温度:-40℃~+140℃
Insulation Class: Class F / Working Temperature: -40℃~+140℃
认证: CE 和 ROHS Certifications: CE and ROHS

电机主要性能参数 Motor Main Characteristics:

型号Model	单位 Unit	80ZYT01A	80ZYT02A	80ZYT03A
额定电压 Rated Voltage	VDC	24v (可定制直流12v到230v) ; 24v (option for 12v up to 230vdc)		
额定转速 Rated Speed	Rpm	2900	2900	3000
额定力矩 Rated Torque	N.m	0.6	0.8	1.0
空载转速 No Load Speed	Rpm	3600	3600	3600
重量 Weight	Kg	2.8	3.2	3.7
机身长度 Motor Length	Mm	120	140	160
额定输出功率 Output Power	W	182	243	314

行星齿轮箱主要性能参数 Planetary Gearbox Specifications:型号 Gearbox Model: 60JXE450K

内齿圈材料 Ring material	E 型:金属 Met
输出轴轴承形式 Bearing at output	滚动轴承Ball bearing
最大允许径向负载(离法兰10mm处) Max. Radial load (10mm from flange)	≤400N
最大允许轴向负载Max. shaft axial load	≤120N
径向间隙 (测量点尽量接近法兰) Radial play of shaft (near to flange)	≤0.08mm
轴向间隙 Axial play of shaft	≤0.4mm
背隙 (无负载时) Backlash at no-load	≤1.5°
输出轴最大承受压入力 Shaft press fit force max	≤300N

减速比 Reduction ratio	额定允许负载 Rated tolerance torque	瞬间允许负载 Max momentary tolerance torque	效率 Efficiency	L (mm)	重量 (g) Weight(g)
1/3.6 1/4.25 1/5.33	4 N.m	12 N.m	90%	40.3±0.5	520
1/13 1/15 1/18 1/23 1/28	18 N.m	36 N.m	81%	53.8±0.5	710
1/43 1/52 1/61 1/72 1/96 1/121	36 N.m	72 N.m	73%	67.2±0.5	900
1/154 1/187 1/220 1/260 1/307	45 N.m	90N.m	66%	80.6±0.5	1100
1/409 1/514 1/645 1/809					

图纸 Drawing

60JXE450K.80ZYT Series

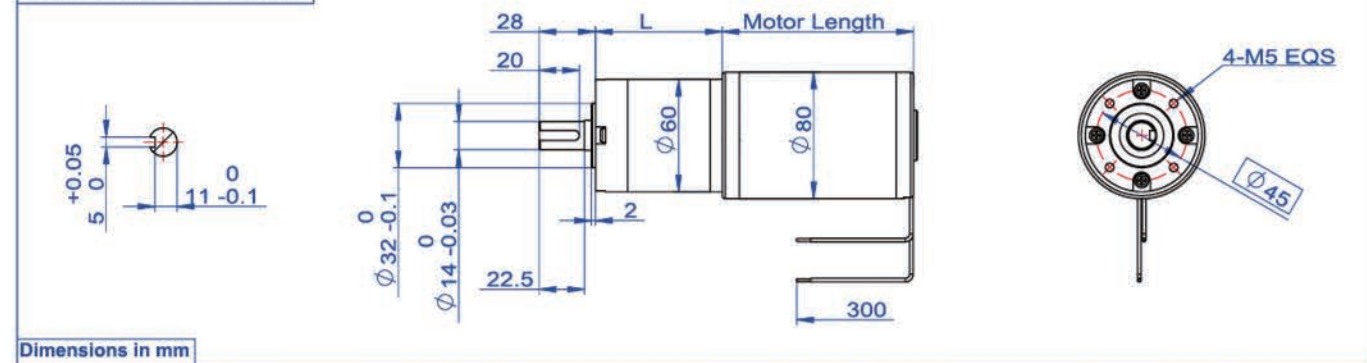

直流有刷行星减速电机82PN.90ZYT 系列 (斜齿齿轮箱, 大扭矩)
Brush DC Planetary Gear Motor 82PN.90ZYT Series (Helical Gear, Large Torque)



电机主要规格参数 Motor Specifications:

轴承: 高质量滚珠轴承 Bearing: High Quality Ball Bearing
磁钢: 高性能铁氧体磁钢 4-极 Magnet: Hard Ferrite Magnet, 4- Poles
保护等级: IP50(可选IP54) Protection Class: IP50 (Option for IP54)
绝缘等级: F级 / 工作温度:-40℃~+140℃
Insulation Class: Class F / Working Temperature: -40℃~+140℃
认证: CE 和 ROHS Certifications: CE and ROHS

电机主要性能参数 Motor Main Characteristics:

型号Model	单位 Unit	90ZYT01A	90ZYT-180	90ZYT02A
额定电压 Rated Voltage	VDC	24v (可定制直流12v到230v) ; 24v (option for 12v up to 230vdc)		
额定转速 Rated Speed	Rpm	3000	3000	3000
额定力矩 Rated Torque	N.m	1.2	1.6	1.8
空载转速 No Load Speed	Rpm	3600	3500	3600
重量 Weight	Kg	3.5	4.0	4.5
机身长度 Motor Length	Mm	155	180	199
额定输出功率 Output Power	W	377	503	565



行星齿轮箱主要性能参数 Planetary Gearbox Specifications:
型号 Gearbox Model: 82PN (斜齿齿轮箱, 大扭矩Helical Gear)

减速比 Reduction ratio	额定允许负载 Rated tolerance torque	瞬间允许负载 Max momentary tolerance torque	效率 Efficiency	L (mm)
1/3.65 1/5.36 1/6.55 1/8.63	20N.m	40 N.m	90%	58.3±0.5
1/13.5 1/18.9 1/24.6 1/28 1/33.9 1/44.7 1/67	60 N.m	120 N.m	81%	80.5±0.5
1/81.1 1/91.3 1/102.9 1/119 1/127.7 1/145.4	120N.m	240 N.m	73%	103.2±0.5

图纸 Drawing

82PN.90ZYT Series

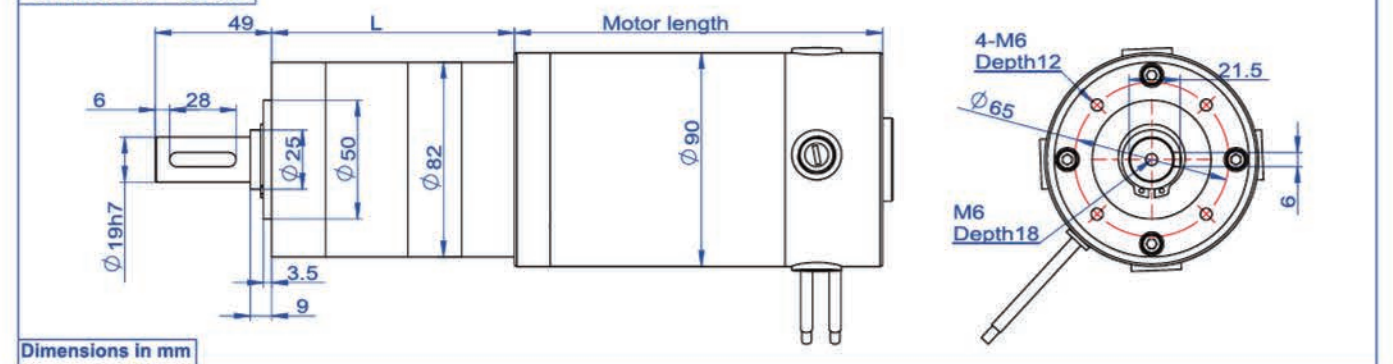

WG5882.42ZYT 系列涡轮蜗杆减速电机 WG5882.42ZYT SERIES DC WORM GEAR MOTOR

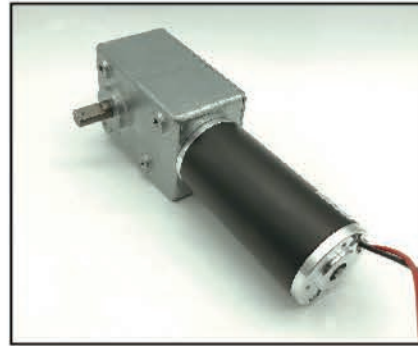

电机主要规格参数 Motor Specifications:

轴承: 高质量滚珠轴承 Bearing: High Quality Ball Bearing
磁钢: 高性能铁氧体磁钢 2-极 Magnet: Hard Ferrite Magnet, 2- Poles
保护等级: IP50 Protection Class: IP50
绝缘等级: F级 / 工作温度: -40°C~+140°C
Insulation Class: Class F / Working Temperature: -40°C~+140°C

电机主要性能参数 Motor Main Characteristics:

型号Model	单位 Unit	42ZYT04A	42ZYT04B	42ZYT04C
额定电压 Rated Voltage	VDC	24v (可定制直流12v到230v) ; 24v (option for 12v up to 230vdc)		
额定转速 Rated Speed	Rpm	3350	4700	8770
额定力矩 Rated Torque	mN.m	70	100	100
空载转速 No Load Speed	Rpm	4000	5900	10000
重量 Weight	G	550	550	550
机身长度 Motor Length	Mm	90	90	90
额定输出功率 Output Power	W	25	49	

WG5882.42ZYT 涡轮蜗杆减速电机参数WG5882.42ZYT Worm Gear Motor Specification

减速比 Reduction ratio		176:1		
型号Model		WG5882.42ZYT04A	WG5882.42ZYT04B	WG5882.42ZYT04C
效率 Transmission Efficiency		50%	50%	50%
空载转速 No Load Speed	Rpm	23	34	57
额定转速 Rated Speed	Rpm	19	27	50
额定力矩 Rated Torque	N.m	6.2	8.8	8.8

图纸 Drawing

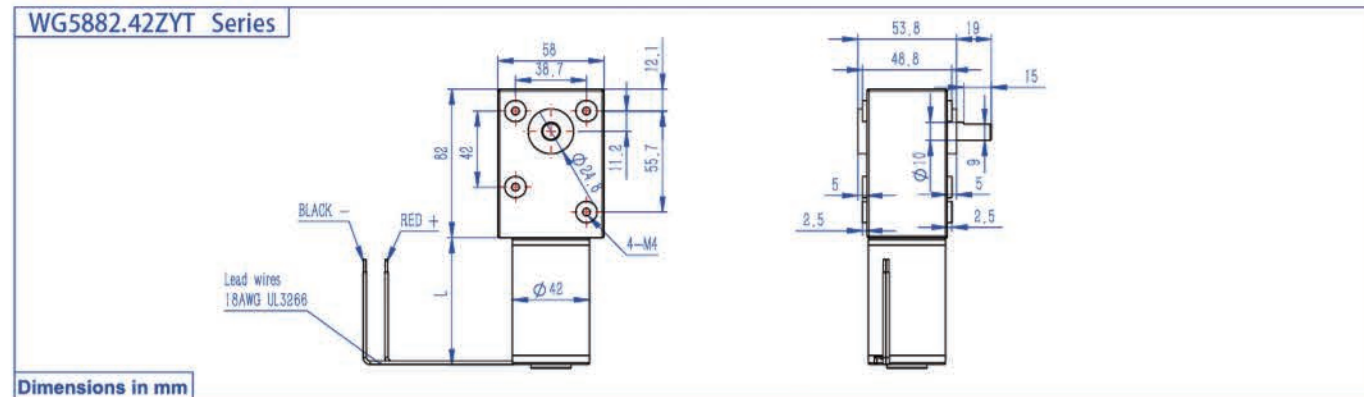

63WG.63ZYT系列涡轮蜗杆减速电机 63WG.63ZYT SERIES PM DC WORM GEAR MOTOR



电机主要规格参数 Motor Specifications:

轴承: 高质量滚珠轴承 Bearing: High Quality Ball Bearing
磁钢: 高性能铁氧体磁钢 2-极 Magnet: Hard Ferrite Magnet, 2- Poles
保护等级: IP50(可选IP54) Protection Class: IP50 (Option for IP54)
绝缘等级: F级 / 工作温度: -40°C~+140°C
Insulation Class: Class F / Working Temperature: -40°C~+140°C

电机主要性能参数 Motor Main Characteristics:

型号Model	单位 Unit	63ZYT01A/01L	63ZYT02A/02L	63ZYT03A/03L			
额定电压 Rated Voltage	VDC	24v (可定制直流12V到48V) ; 24v (option for 12v up to 48vdc)					
额定转速 Rated Speed	Rpm	3100	1550	3000	1800	3000	2000
额定力矩 Rated Torque	N.m	0.15	0.15	0.31	0.31	0.41	0.4
空载转速 No Load Speed	Rpm	3600	1800	3500	2400	3500	2600
重量 Weight	Kg	1	1	1.2	1.2	1.35	1.35
机身长度 Motor Length	Mm	95	95	110	110	125	125
额定输出功率 Output Power	W	50	16	98	60	25	86

63WG.63ZYT 涡轮蜗杆减速电机参数63WG.63ZYT Worm Gear Motor Specifications:

型号Model		63WG.63ZYT01A			63WG.63ZYT01L		
减速比 Reduction ratio		10	15	30	10	15	30
效率 Transmission Efficiency		70%	69.8%	69.3%	70%	69.8%	69.3%
空载转速 No Load Speed	Rpm	360	240	120	180	120	60
额定转速 Rated Speed	Rpm	310	207	103	155	103	52
额定力矩 Rated Torque	N.m	1.05	1.57	3.12	1.05	1.57	3.12
型号Model		63WG.63ZYT02A			63WG.63ZYT02L		
减速比 Reduction ratio		10	15	30	10	15	30
效率 Transmission Efficiency		70%	69.8%	69.3%	70%	69.8%	69.3%
空载转速 No Load Speed	Rpm	350	223	117	240	160	80
额定转速 Rated Speed	Rpm	300	200	100	180	120	60
额定力矩 Rated Torque	N.m	2.17	3.25	6.44	2.17	3.25	6.44
型号Model		63WG.63ZYT03A			63WG.63ZYT03L		
减速比 Reduction ratio		10	15	30	10	15	30
效率 Transmission Efficiency		70%	69.8%	69.3%	70%	69.8%	69.3%
空载转速 No Load Speed	Rpm	350	233	117	260	173	87
额定转速 Rated Speed	Rpm	300	200	100	200	133	67
额定力矩 Rated Torque	N.m	2.8	4.19	8	2.8	4.19	8

图纸 Drawing

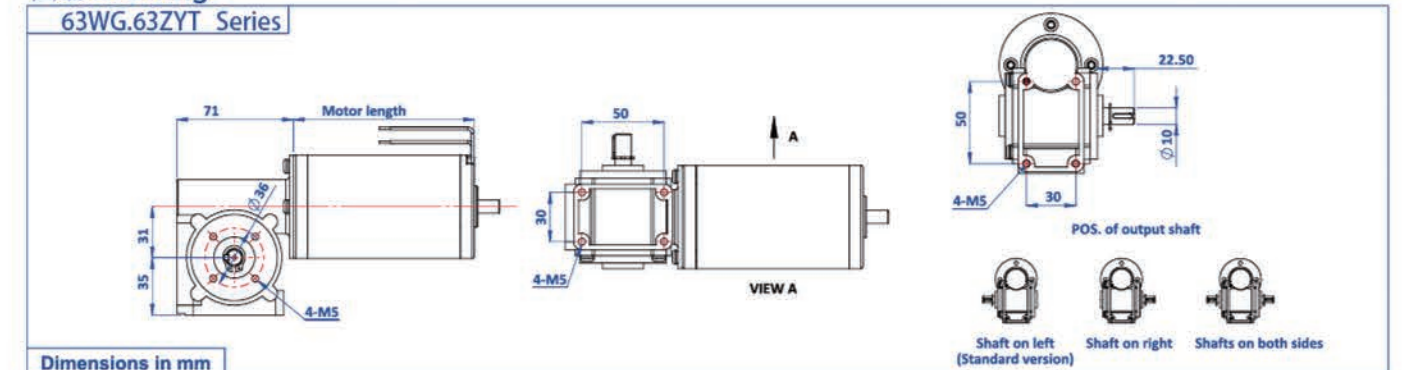

NMRV30.80ZYT 系列涡轮蜗杆减速电机 NMRV30.80ZYT SERIES PM DC WORM GEAR MOTOR

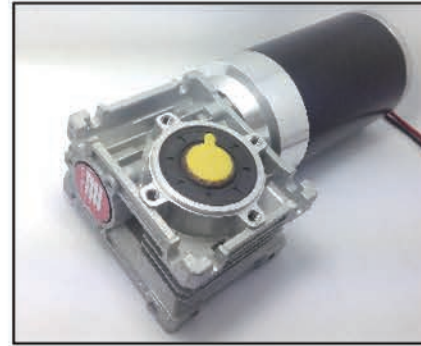

电机主要规格参数 Motor Specifications:

轴承: 高质量滚珠轴承 Bearing: High Quality Ball Bearing
磁钢: 高性能铁氧体磁钢 2-极 Magnet: Hard Ferrite Magnet, 2- Poles
保护等级: IP50(可选IP54) Protection Class: IP50 (Option for IP54)
绝缘等级: F级 / 工作温度: -40℃~+140℃
Insulation Class: Class F / Working Temperature: -40℃~+140℃

电机主要性能参数 Motor Main Characteristics:

型号Model	单位 Unit	80ZYT01L	80ZYT02L	80ZYT03L
额定电压 Rated Voltage	VDC	24v (可定制直流12V到48V) ; 24v (option for 12v up to 48vdc)		
额定转速 Rated Speed	Rpm	1400	1400	1400
额定力矩 Rated Torque	N.m	0.35	0.50	0.70
空载转速 No Load Speed	Rpm	1800	1800	1800
重量 Weight	Kg	2.8	3.2	3.7
机身长度 Motor Length	Mm	120	140	160
额定输出功率 Output Power	W	50	75	100

NMRV30.80ZYT01L 涡轮蜗杆减速电机参数 NMRV30.80ZYT01L Worm Gear Motor Specification:

减速比 Reduction ratio		5	7.5	10	15	20	25	30	40	50	60	80
效率 Transmission Efficiency		90%	85%	85%	80%	75%	75%	70%	65%	60%	55%	50%
空载转速 No Load Speed	Rpm	360	240	180	120	90	72	60	45	36	30	22.5
额定转速 Rated Speed	Rpm	280.0	186.7	140.0	93.3	70.0	56.0	46.7	35.0	28.0	23.3	17.5
额定力矩 Rated Torque	N.m	1.6	2.2	3.0	4.2	5.3	6.6	7.4	9.1	10.0	11.0	14.0

NMRV30.80ZYT02L 涡轮蜗杆减速电机参数 NMRV30.80ZYT02L Worm Gear Motor Specification:

减速比 Reduction ratio		5	7.5	10	15	20	25	30	40	50	60	80
效率 Transmission Efficiency		90%	85%	85%	80%	75%	75%	70%	65%	60%	55%	50%
空载转速 No Load Speed	Rpm	360	240	180	120	90	72	60	45	36	30	22.5
额定转速 Rated Speed	Rpm	280.0	186.7	140.0	93.3	70.0	56.0	46.7	35.0	28.0	23.3	17.5
额定力矩 Rated Torque	N.m	2.3	3.2	4.3	6.0	7.5	9.4	10.5	13.0	15.0	16.5	20.0

NMRV30.80ZYT03L 涡轮蜗杆减速电机参数 NMRV30.80ZYT03L Worm Gear Motor Specification:

减速比 Reduction ratio		5	7.5	10	15	20	25	30	40	50	60	80
效率 Transmission Efficiency		90%	85%	85%	80%	75%	75%	70%	65%	60%	55%	50%
空载转速 No Load Speed	Rpm	360	240	180	120	90	72	60	45	36	30	22.5
额定转速 Rated Speed	Rpm	280.0	186.7	140.0	93.3	70.0	56.0	46.7	35.0	28.0	23.3	17.5
额定力矩 Rated Torque	N.m	3.2	4.5	6.0	8.4	10.5	13.1	14.7	18.2	21.0	23.1	28.0

图纸 Drawing

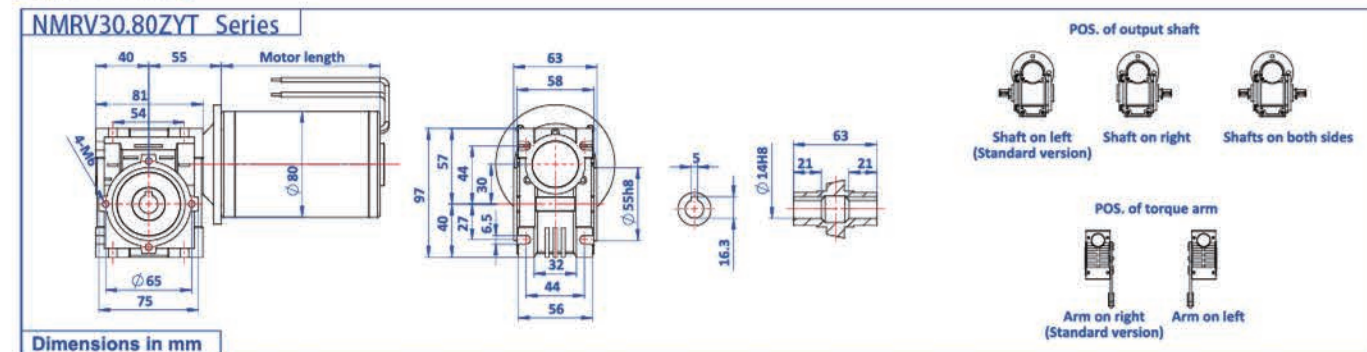

NMRV40.80ZYT 系列涡轮蜗杆减速电机 NMRV40.80ZYT SERIES PM DC WORM GEAR MOTOR



电机主要规格参数 Motor Specifications:

轴承: 高质量滚珠轴承 Bearing: High Quality Ball Bearing
磁钢: 高性能铁氧体磁钢 2-极 Magnet: Hard Ferrite Magnet, 2- Poles
保护等级: IP50(可选IP54) Protection Class: IP50 (Option for IP54)
绝缘等级: F级 / 工作温度: -40℃~+140℃
Insulation Class: Class F / Working Temperature: -40℃~+140℃

电机主要性能参数 Motor Main Characteristics:

型号Model	单位 Unit	80ZYT01M	80ZYT02M	80ZYT03M
额定电压 Rated Voltage	VDC	24v (可定制直流12V到48V) ; 24v (option for 12v up to 48vdc)		
额定转速 Rated Speed	Rpm	2500	2500	2500
额定力矩 Rated Torque	N.m	0.6	0.8	1.0
空载转速 No Load Speed	Rpm	3200	3200	3200
重量 Weight	Kg	2.8	3.2	3.7
机身长度 Motor Length	Mm	120	140	160
额定输出功率 Output Power	W	50	75	100

NMRV40.80ZYT01M 涡轮蜗杆减速电机参数 NMRV40.80ZYT01M Worm Gear Motor Specification:

减速比 Reduction ratio		5	7.5	10	15	20	25	30	40	50	60	80
效率 Transmission Efficiency		90%	85%	85%	80%	75%	75%	70%	65%	60%	55%	50%
空载转速 No Load Speed	Rpm	640	427	320	213	160	128	107	80	64	53	40
额定转速 Rated Speed	Rpm	500	333	250	167	125	100	83	63	50	42	31
额定力矩 Rated Torque	N.m	2.7	3.8	5.1	7.2	9.0	11.3	12.6	15.6	18.0	19.8	24.0

NMRV40.80ZYT02M 涡轮蜗杆减速电机参数 NMRV40.80ZYT02M Worm Gear Motor Specification:

减速比 Reduction ratio		5	7.5	10	15	20	25	30	40	50	60	80
效率 Transmission Efficiency		90%	85%	85%	80%	75%	75%	70%	65%	60%	55%	50%
空载转速 No Load Speed	Rpm	640	427	320	213	160	128	107	80	64	53	40
额定转速 Rated Speed	Rpm	500	333	250	167	125	100	83	63	50	42	31
额定力矩 Rated Torque	N.m	3.6	5.1	6.8	9.6	12.0	15.0	16.8	20.8	24.0	26.4	32.0

NMRV40.80ZYT03M 涡轮蜗杆减速电机参数 NMRV40.80ZYT03M Worm Gear Motor Specification:

减速比 Reduction ratio		5	7.5	10	15	20	25	30	40	50	60	80
效率 Transmission Efficiency		90%	85%	85%	80%	75%	75%	70%	65%	60%	55%	50%
空载转速 No Load Speed	Rpm	640	427	320	213	160	128	107	80	64	53	40
额定转速 Rated Speed	Rpm	500	333	250	167	125	100	83	63	50	42	31
额定力矩 Rated Torque	N.m	4.5	6.4	8.5	12.0	15.0	18.8	21.0	26.0	30.0	33.0	40.0

图纸 Drawing

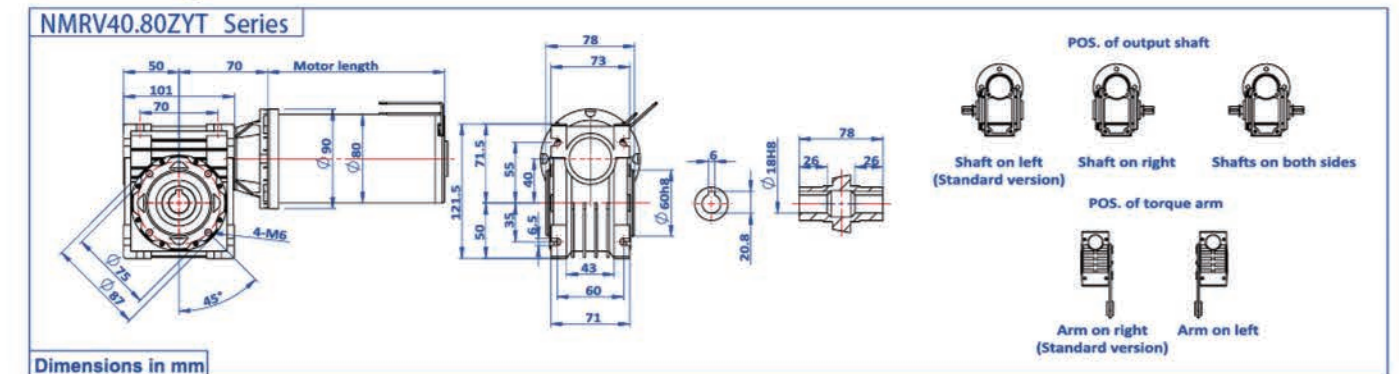

NMRV30.80ZYT-R 可更换碳刷80系列涡轮蜗杆减速电机 NMRV30.80ZYT-R SERIES PM DC WORM GEAR MOTOR (Replaceable, Big Brushes)

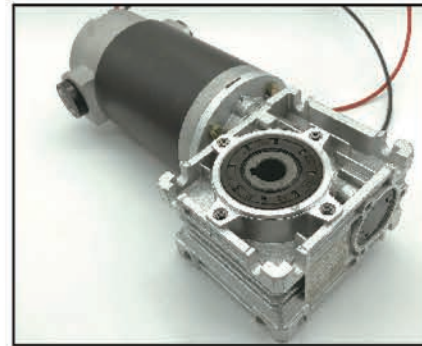

电机主要规格参数 Motor Specifications:

轴承: 高质量滚珠轴承 Bearing: High Quality Ball Bearing
磁钢: 高性能铁氧体磁钢 2-极 Magnet: Hard Ferrite Magnet, 2- Poles
保护等级: IP50(可选IP54) Protection Class: IP50 (Option for IP54)
绝缘等级: F级 / 工作温度:-40℃~+140℃
Insulation Class: Class F / Working Temperature: -40℃~+140℃

电机主要性能参数 Motor Main Characteristics:

型号Model	单位 Unit	80ZYT-R01	80ZYT-R02	80ZYT-R03
额定电压 Rated Voltage	VDC	24v (可定制直流12v到120v) ; 24v (option for 12v up to 120vdc)		
额定转速 Rated Speed	Rpm	2600	2600	2600
额定力矩 Rated Torque	N.m	0.45	0.65	0.85
空载转速 No Load Speed	Rpm	2900	2900	2900
重量 Weight	Kg	3.0	3.2	3.4
机身长度 Motor Length	Mm	140	160	180
额定输出功率 Output Power	W	122	177	231

NMRV30.80ZYT-R01 涡轮蜗杆减速电机参数NMRV30.80ZYT-R01 Worm Gear Motor Specification:

减速比 Reduction ratio		5	7.5	10	15	20	25	30	40	50	60	80
效率 Transmission Efficiency		90%	85%	85%	80%	75%	75%	70%	65%	60%	55%	50%
空载转速 No Load Speed	Rpm	580	387	290	193	145	116	97	73	58	48	36
额定转速 Rated Speed	Rpm	520	347	260	173	130	104	87	65	52	43	33
额定力矩 Rated Torque	N.m	2.0	2.9	3.8	5.4	6.8	8.4	9.5	11.7	13.9	16.0	21.5

NMRV30.80ZYT-R02 涡轮蜗杆减速电机参数NMRV30.80ZYT-R02 Worm Gear Motor Specification:

减速比 Reduction ratio		5	7.5	10	15	20	25	30	40	50	60	80
效率 Transmission Efficiency		90%	85%	85%	80%	75%	75%	70%	65%	60%	55%	50%
空载转速 No Load Speed	Rpm	580	387	290	193	145	116	97	73	58	48	36
额定转速 Rated Speed	Rpm	520	347	260	173	130	104	87	65	52	43	33
额定力矩 Rated Torque	N.m	2.9	4.1	5.5	7.8	9.8	12.2	13.7	16.9	19.5	21.5	26.0

NMRV30.80ZYT-R03 涡轮蜗杆减速电机参数NMRV30.80ZYT-R03 Worm Gear Motor Specification:

减速比 Reduction ratio		5	7.5	10	15	20	25	30	40	50	60	80
效率 Transmission Efficiency		90%	85%	85%	80%	75%	75%	70%	65%	60%	55%	50%
空载转速 No Load Speed	Rpm	580	387	290	193	145	116	97	73	58	48	36
额定转速 Rated Speed	Rpm	520	347	260	173	130	104	87	65	52	43	33
额定力矩 Rated Torque	N.m	3.8	5.4	7.2	10.2	12.8	15.9	17.9	22.1	25.5	28.1	34.0

图纸 Drawing

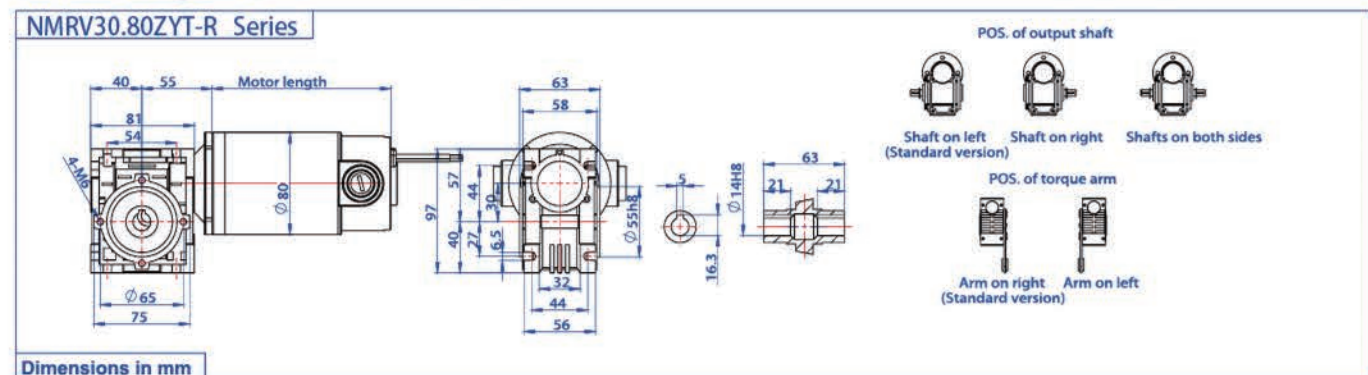

NMRV40.90ZYT 系列涡轮蜗杆减速电机 NMRV40.90ZYT SERIES PM DC WORM GEAR MOTOR

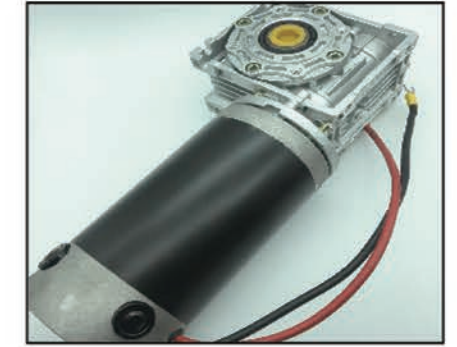

电机主要规格参数 Motor Specifications:

轴承: 高质量滚珠轴承 Bearing: High Quality Ball Bearing
磁钢: 高性能铁氧体磁钢 4-极 Magnet: Hard Ferrite Magnet, 4- Poles
保护等级: IP50(可选IP54) Protection Class: IP50 (Option for IP54)
绝缘等级: F级 / 工作温度:-40℃~+140℃
Insulation Class: Class F / Working Temperature: -40℃~+140℃

电机主要性能参数 Motor Main Characteristics:

型号Model	单位 Unit	90ZYT01L	90ZYT-180L	90ZYT02L
额定电压 Rated Voltage	VDC	24v (可定制直流12V到230V) ; 24v (option for 12v up to 230vdc)		
额定转速 Rated Speed	Rpm	1500	1500	1500
额定力矩 Rated Torque	N.m	1.0	1.25	1.5
空载转速 No Load Speed	Rpm	2000	2000	2000
重量 Weight	Kg	3.5	4.0	4.5
机身长度 Motor Length	Mm	155	180	199
额定输出功率 Output Power	W	160	200	236

NMRV40.90ZYT01L 涡轮蜗杆减速电机参数NMRV40.90ZYT01L Worm Gear Motor Specification:

减速比 Reduction ratio		5	7.5	10	15	20	25	30	40	50	60	80	100
效率 Transmission Efficiency		90%	85%	85%	80%	75%	75%	70%	65%	60%	55%	50%	50%
空载转速 No Load Speed	Rpm	400.0	266.7	200.0	133.3	100.0	80.0	66.7	50.0	40.0	33.3	25.0	20.0
额定转速 Rated Speed	Rpm	300.0	200.0	150.0	100.0	75.0	60.0	50.0	37.5	30.0	25.0	18.8	15.0
额定力矩 Rated Torque	N.m	4.5	6.4	8.5	12.0	15.0	18.8	21.0	26.0	30.0	33.0	40.0	50.0

NMRV40.90ZYT-180 涡轮蜗杆减速电机参数NMRV40.90ZYT-180 Worm Gear Motor Specification:

减速比 Reduction ratio		5	7.5	10	15	20	25	30	40	50	60	80	100
效率 Transmission Efficiency		90%	85%	85%	80%	75%	75%	70%	65%	60%	55%	50%	50%
空载转速 No Load Speed	Rpm	400.0	266.7	200.0	133.3	100.0	80.0	66.7	50.0	40.0	33.3	25.0	20.0
额定转速 Rated Speed	Rpm	300.0	200.0	150.0	100.0	75.0	60.0	50.0	37.5	30.0	25.0	18.8	15.0
额定力矩 Rated Torque	N.m	5.6	8.0	10.6	15.0	18.8	23.4	26.3	32.5	37.5	41.3	50.0	62.5

NMRV40.90ZYT02L 涡轮蜗杆减速电机参数NMRV40.90ZYT02L Worm Gear Motor Specification:

减速比 Reduction ratio		5	7.5	10	15	20	25	30	40	50	60	80	100
效率 Transmission Efficiency		90%	85%	85%	80%	75%	75%	70%	65%	60%	55%	50%	50%
空载转速 No Load Speed	Rpm	400.0	266.7	200.0	133.3	100.0	80.0	66.7	50.0	40.0	33.3	25.0	20.0
额定转速 Rated Speed	Rpm	300.0	200.0	150.0	100.0	75.0	60.0	50.0	37.5	30.0	25.0	18.8	15.0
额定力矩 Rated Torque	N.m	6.7	9.6	12.8	18.0	22.5	28.1	31.5	39.0	45.0	49.5	60.0	70.0

图纸 Drawing

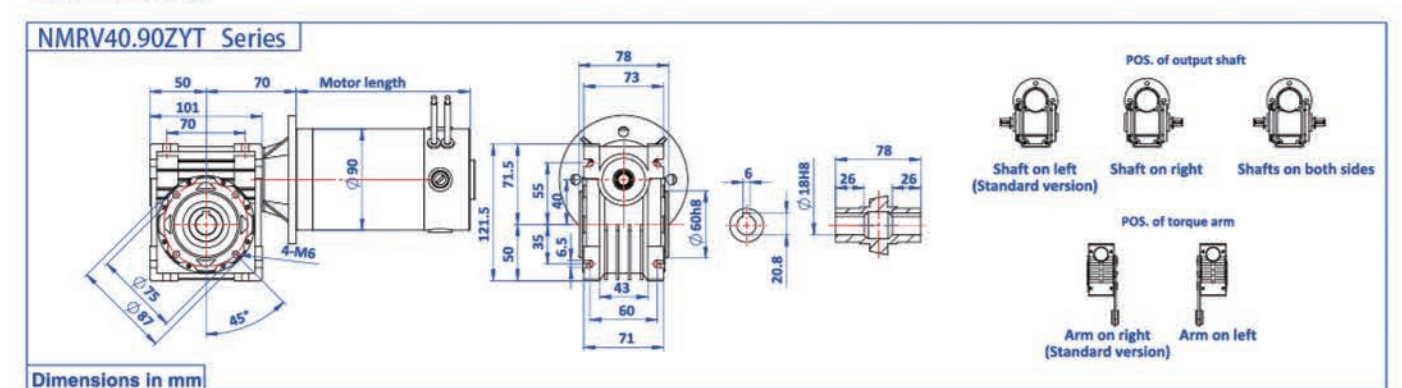

NMRV50.90ZYT 系列涡轮蜗杆减速电机 NMRV50.90ZYT SERIES PM DC WORM GEAR MOTOR



电机主要规格参数 Motor Specifications:

轴承: 高质量滚珠轴承 Bearing: High Quality Ball Bearing
 磁钢: 高性能铁氧体磁钢 4-极 Magnet: Hard Ferrite Magnet, 4- Poles
 保护等级: IP50(可选IP54) Protection Class: IP50 (Option for IP54)
 绝缘等级: F级 / 工作温度: -40℃~+140℃
 Insulation Class: Class F / Working Temperature: -40℃~+140℃

电机主要性能参数 Motor Main Characteristics:

型号Model	单位Unit	90ZYT01M	90ZYT-180M	90ZYT02M
额定电压 Rated Voltage	VDC	24v (可定制直流12V到230V) ; 24v (option for 12v up to 230vdc)		
额定转速 Rated Speed	Rpm	2500	2500	2500
额定力矩 Rated Torque	N.m	1.2	1.6	1.8
空载转速 No Load Speed	Rpm	3150	3150	3150
重量 Weight	Kg	3.5	4.0	4.5
机身长度 Motor Length	Mm	155	180	199
额定输出功率 Output Power	W	315	420	473

NMRV50. 90ZYT01M 涡轮蜗杆减速电机参数 NMRV50. 90ZYT01M Worm Gear Motor Specification:

减速比 Reduction ratio	5	7.5	10	15	20	25	30	40	50	60	80	100
效率 Transmission Efficiency	90%	85%	85%	80%	75%	75%	70%	65%	60%	55%	50%	50%
空载转速 No Load Speed	Rpm	630	427	320	213	160	128	107	80	64	53	42
额定转速 Rated Speed	Rpm	500	333	250	167	125	100	83	63	50	42	31
额定力矩 Rated Torque	N.m	5.4	8.0	10.6	15.0	18.8	23.4	26.3	32.5	37.5	41.0	60.0

NMRV50. 90ZYT-180M 涡轮蜗杆减速电机参数 NMRV50. 90ZYT-180M Worm Gear Motor Specification:

减速比 Reduction ratio	5	7.5	10	15	20	25	30	40	50	60	80	100
效率 Transmission Efficiency	90%	85%	85%	80%	75%	75%	70%	65%	60%	55%	50%	50%
空载转速 No Load Speed	Rpm	630	427	320	213	160	128	107	80	64	53	40
额定转速 Rated Speed	Rpm	500	333	250	167	125	100	83	63	50	42	31
额定力矩 Rated Torque	N.m	7.2	10.2	13.6	19.2	24.0	30.0	33.6	41.6	48.0	52.8	80.0

NMRV50. 90ZYT02M 涡轮蜗杆减速电机参数 NMRV50. 90ZYT02M Worm Gear Motor Specification:

减速比 Reduction ratio	5	7.5	10	15	20	25	30	40	50	60	80	100
效率 Transmission Efficiency	90%	85%	85%	80%	75%	75%	70%	65%	60%	55%	50%	50%
空载转速 No Load Speed	Rpm	630	427	320	213	160	128	107	80	64	53	40
额定转速 Rated Speed	Rpm	500	333	250	167	125	100	83	63	50	42	31
额定力矩 Rated Torque	N.m	8.1	11.5	15.3	21.6	27.0	33.8	37.8	46.8	54.0	59.4	90.0

图纸 Drawing

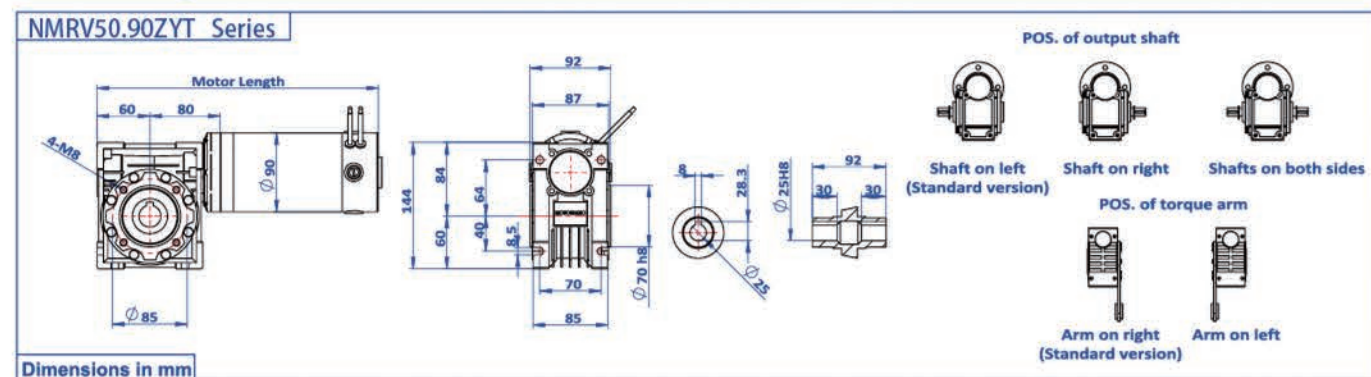

28BL 系列无刷直流电机 28BL Series Brushless Dc Motor

常规性能 General specification

项目Item	参数Specification
接线样式 Winding type	Star
霍尔作用角度 Hall effect angle	120° (电气角度 electrical angle)
轴向跳动 Shaft run out	0.025mm
径向间隙 Radial play	0.02mm@450g
轴向间隙 End play	0.08mm@450g
最大径向负载 Max. radial force	15N@10mm from the flange
最大轴向负载 Max. axial force	10N
绝缘等级 Insulation class	Class B
介电强度 Dielectric Strength	500VDC for one minute
绝缘电阻 Insulation resistance	100MΩ Min.500VDC

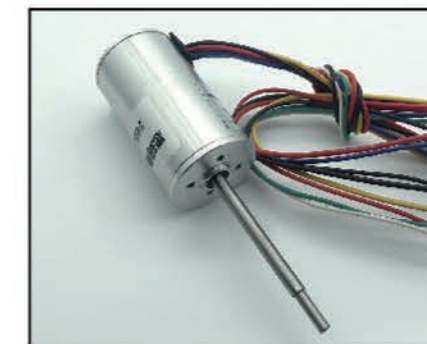

接线方式 Electric connection

顺序 Lead No.	颜色 Lead Color	线规 Lead Gauge	功能 Function	描述 DESCRIPTION
1	红 Red	UL1007/26AWG	VCC	霍尔电源 SUPPLY VOLTAGE FOR HALL SENSORS
2	黑 Black		GND	霍尔接地 GROUND FOR HALL SENSORS
3	黄 Yellow		HALL A	
4	绿 Green		HALL B	
5	蓝 Blue	UL1007/22AWG	HALL C	
6	黄 Yellow		PHASE U	
7	绿 Green		PHASE V	
8	蓝 Blue		PHASE W	



规格参数 Technique Specification

型号 Model	28BL01A	28BL02A	28BL03A
相数 Number of phase	3		
极数 Number of pole	4		
额定电压 Voltage	24v(可定制12v 到48v); 24v(Option for 12v up to 48vdc)		
空载转速 No load speed	8000	8000	8000
额定力矩 Rated torque	10	15	20
额定转速 Rated Speed	6000	6000	6000
额定电流 Rated Current	1.8	2.6	3.6
额定功率 Rated Power	7	10	15
电机重量 Weight	82	105	128
机身长度 Length	39	49	59

机械尺寸 Dimensions

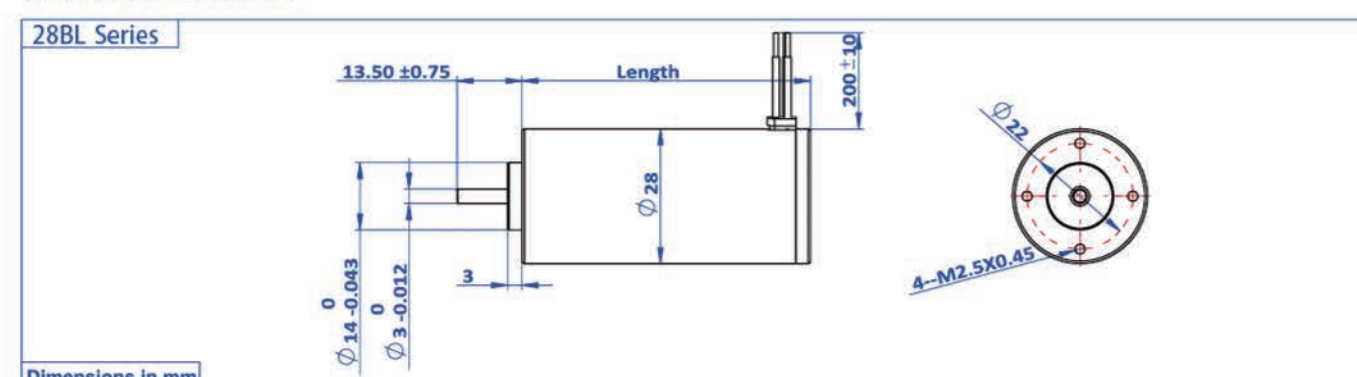

36BL 系列无刷直流电机 36BL Series Brushless Dc Motor

常规性能General specification

项目Item	参数Specification
接线样式Winding type	Star
霍尔作用角度Hall effect angle	120° (电气角度electrical angle)
轴向跳动Shaft run out	0.025mm
径向间隙Radial play	0.02mm@450g
轴向间隙End play	0.08mm@450g
最大径向负载Max. radial force	15N@10mm from the flange
最大轴向负载Max. axial force	10N
绝缘等级Insulation class	Class B
介电强度Dielectric Strength	500VDC for one minute
绝缘电阻Insulation resistance	100MΩ Min.500VDC



接线方式 Electric connection

顺序Lead No.	颜色Lead Color	线规Lead Gauge	功能Function	描述DESCRIPTION
1	红Red	UL1007/26AWG	VCC	霍尔电源SUPPLY VOLTAGE FOR HALL SENSORS
2	黑Black		GND	霍尔接地GROUND FOR HALL SENSORS
3	黄Yellow		HALL A	
4	绿Green	UL1007/22AWG	HALL B	
5	蓝Blue		HALL C	
6	黄Yellow		PHASE U	
7	绿Green		PHASE V	
8	蓝Blue		PHASE W	

规格参数Technique Specification

型号Model	36BL01A	36BL02A	36BL03A
相数Number of phase	3		
极数 Number of pole	4		
额定电压Voltage	V 24v(可定制12v 到48v); 24v(Option for 12v up to 48vdc)		
空载转速No load speed	rpm 6200	8000	9500
额定力矩Rated torque	mNm 36	60	75
额定转速Rated Speed	rpm 4800	6000	8000
额定电流Rated Current	A 2	3.5	4.5
额定功率Rated Power	W 18	40	63
电机重量Weight	g 185	210	250
机身长度Length	mm 45	55	65

机械尺寸Dimensions

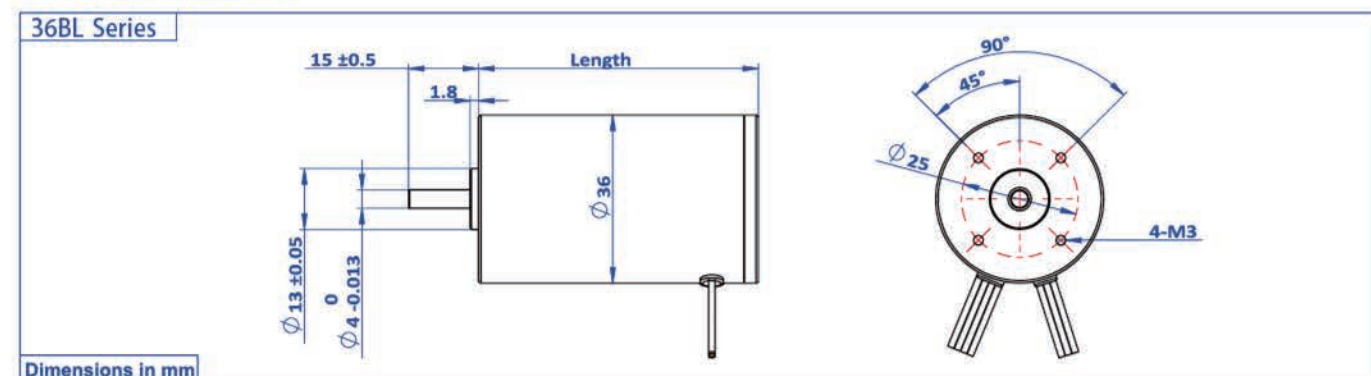

42BLS 系列无刷直流电机 42BLS Series Brushless Dc Motor

常规性能General specification

项目Item	参数Specification
接线样式Winding type	Delta
霍尔作用角度Hall effect angle	120° (电气角度electrical angle)
轴向跳动Shaft run out	0.025mm
径向间隙Radial play	0.02mm@450g
轴向间隙End play	0.08mm@450g
最大径向负载Max. radial force	28N@20mm from the flange
最大轴向负载Max. axial force	10N
绝缘等级Insulation class	Class B
介电强度Dielectric Strength	500VDC for one minute
绝缘电阻Insulation resistance	100MΩ Min.500VDC



接线方式 Electric connection

顺序Lead No.	颜色Lead Color	线规Lead Gauge	功能Function	描述DESCRIPTION
1	红Red	UL1007/26AWG	VCC	霍尔电源SUPPLY VOLTAGE FOR HALL SENSORS
2	黑Black		GND	霍尔接地GROUND FOR HALL SENSORS
3	黄Yellow		HALL A	
4	绿Green	UL1007/22AWG	HALL B	
5	蓝Blue		HALL C	
6	黄Yellow		PHASE U	
7	绿Green		PHASE V	
8	蓝Blue		PHASE W	

规格参数Technique Specification

型号Model	42BLS01A	42BLS02A	42BLS03A	42BLS04A
相数Number of phase	3			
极数 Number of pole	8			
额定电压Voltage	V 24v(可定制12v 到48v); 24v(Option for 12v up to 48vdc)			
空载转速No load speed	rpm 5000	5000	5000	5000
额定力矩Rated torque	Nm 0.063	0.125	0.185	0.25
额定转速Rated Speed	rpm 4000	4000	4000	4000
额定电流Rated Current	A 1.7	3.5	4.6	6
额定功率Rated Power	W 26	52	77	104
电机重量Weight	Kg 0.3	0.45	0.65	0.75
机身长度Length	mm 41	61	81	100

机械尺寸Dimensions

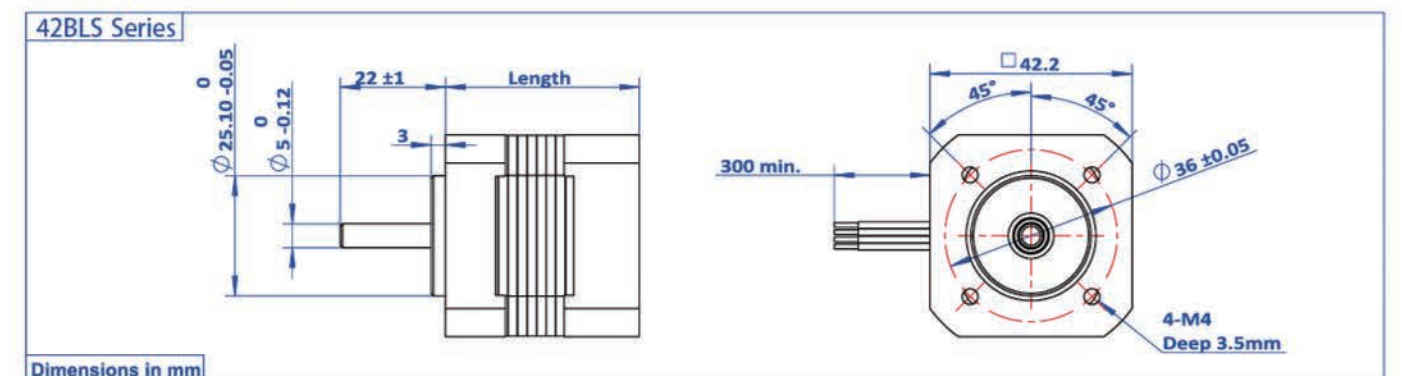

42RBL系列圆形无刷直流电机 42RBL Series Round Type 42mm Brushless Dc Motor

常规性能General specification

项目Item	参数Specification
接线样式Winding type	Star
霍尔作用角度Hall effect angle	120° (电气角度electrical angle)
轴向跳动Shaft run out	0.025mm
径向间隙Radial play	0.025mm@450g
轴向间隙End play	0.08mm@450g
最大径向负载Max. radial force	28N@20mm from the flange
最大轴向负载Max. axial force	10N
绝缘等级Insulation class	Class B
介电强度Dielectric Strength	500VDC for one minute
绝缘电阻Insulation resistance	100MΩ Min.500VDC

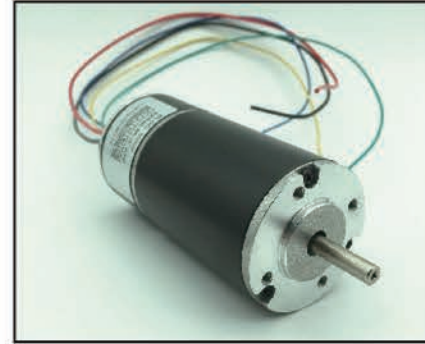

接线方式 Electric connection

顺序Lead No.	颜色Lead Color	线规Lead Gauge	功能Function	描述DESCRIPTION
1	红Red	UL1007/26AWG	VCC	霍尔电源SUPPLY VOLTAGE FOR HALL SENSORS
2	黑Black		GND	霍尔接地GROUND FOR HALL SENSORS
3	黄Yellow		HALL A	
4	绿Green		HALL B	
5	蓝Blue		HALL C	
6	黄Yellow	UL1007/22AWG	PHASE U	
7	绿Green		PHASE V	
8	蓝Blue		PHASE W	

规格参数Technique Specification

型号Model	42RBL01A	42RBL02A	42RBL03A	42RBL04A
相数Number of phase	3			
极数 Number of pole	8			
额定电压Voltage	V 24v(可定制12v 到48v); 24v(Option for 12v up to 48vdc)			
空载转速No load speed	rpm 5200	5200	5200	5200
额定力矩Rated torque	Nm 0.018	0.08	0.15	0.2
额定转速Rated Speed	rpm 4000	4000	4000	4000
额定电流Rated Current	A 0.5	2	4.2	5.7
额定功率Rated Power	W 7.6	33.5	62	85
电机重量Weight	Kg 0.25	0.4	0.7	0.8
机身长度Length	mm 30	60	85	93

机械尺寸Dimensions

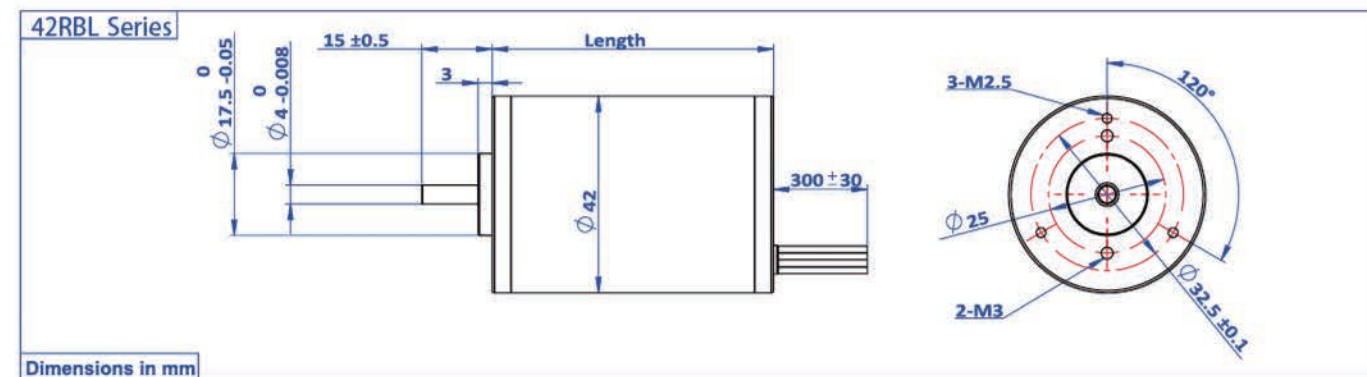

57BL(S) 系列无刷直流电机 57BL(S) Series Brushless Dc Motor

常规性能General specification

项目Item	参数Specification
接线样式Winding type	Star
霍尔作用角度Hall effect angle	120° (电气角度electrical angle)
轴向跳动Shaft run out	0.025mm
径向间隙Radial play	0.025mm@450g
轴向间隙End play	0.025mm@450g
最大径向负载Max. radial force	100N@10mm from the flange
最大轴向负载Max. axial force	15N
绝缘等级Insulation class	Class B
介电强度Dielectric Strength	500VDC for one minute
绝缘电阻Insulation resistance	100MΩ Min.500VDC

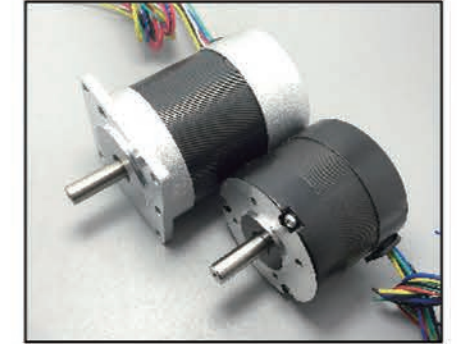

接线方式 Electric connection

顺序Lead No.	颜色Lead Color	线规Lead Gauge	功能Function	描述DESCRIPTION
1	红Red	UL1007/26AWG	VCC	霍尔电源SUPPLY VOLTAGE FOR HALL SENSORS
2	黑Black		GND	霍尔接地GROUND FOR HALL SENSORS
3	黄Yellow		HALL A	
4	绿Green		HALL B	
5	蓝Blue		HALL C	
6	黄Yellow	UL1007/20AWG	PHASE U	
7	绿Green		PHASE V	
8	蓝Blue		PHASE W	

规格参数Technique Specification

型号Model	57BL(S)005A	57BL(S)01A	57BL(S)02A	57BL(S)03A	57BL(S)04A
相数Number of phase	3				
极数 Number of pole	4 (可选8; Option for 8)				
额定电压Voltage	V 36v(可定制12v 24v到115v); 36v(Option for 12v 24v up to 115vdc)				
空载转速No load speed	rpm 5200	5200	5200	5300	5400
额定力矩Rated torque	Nm 0.055	0.11	0.22	0.32	0.42
额定转速Rated Speed	rpm 4000	4000	4000	4000	4000
额定电流Rated Current	A 1	1.8	3.2	4.7	6.5
额定功率Rated Power	W 23.04	46.07	92.15	134.03	175.92
电机重量Weight	Kg 0.28	0.5	0.75	1	1.25
机身长度Length	mm 45	55	75	95	115

机械尺寸Dimensions

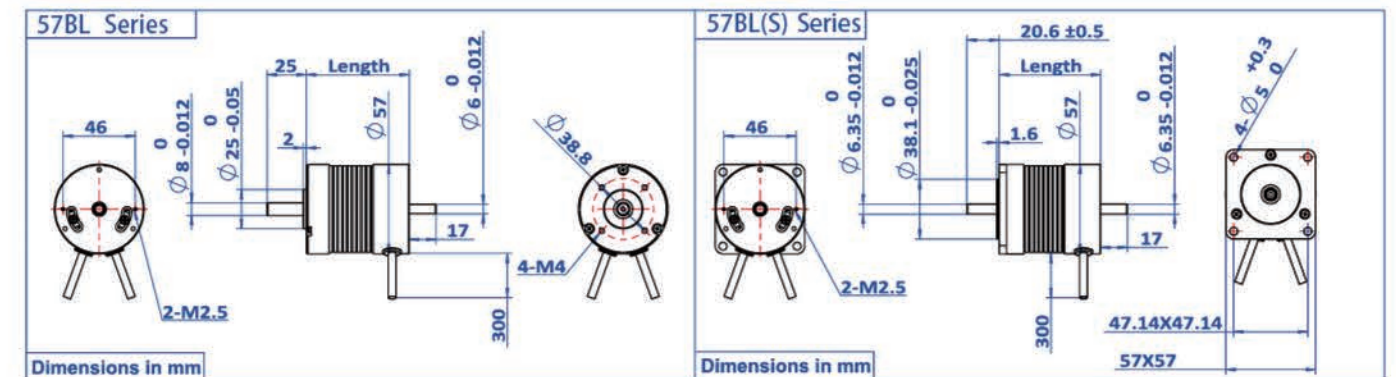

57HBL(S)系列加强型无刷直流电机

57HBL(S) Higher Torque Version 57mm Brushless Dc Motor

常规性能General specification

项目Item	参数Specification
接线样式Winding type	Star
霍尔作用角度Hall effect angle	120° (电气角度electrical angle)
轴向跳动Shaft run out	0.025mm
径向间隙Radial play	0.025mm@450g
轴向间隙End play	0.025mm@450g
最大径向负载Max. radial force	100N@10mm from the flange
最大轴向负载Max. axial force	15N
绝缘等级Insulation class	Class B
介电强度Dielectric Strength	500VDC for one minute
绝缘电阻Insulation resistance	100MΩ Min.500VDC

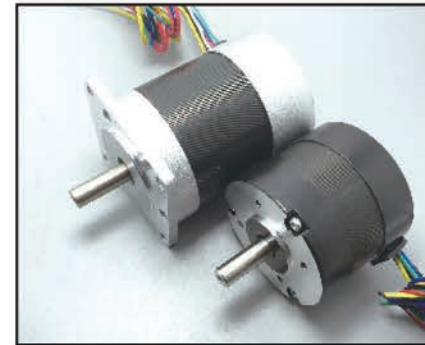

接线方式 Electric connection

顺序Lead No.	颜色Lead Color	线规Lead Gauge	功能Function	描述DESCRIPTION
1	红Red	UL1007/26AWG	VCC	霍尔电源SUPPLY VOLTAGE FOR HALL SENSORS
2	黑Black		GND	霍尔接地GROUND FOR HALL SENSORS
3	黄Yellow		HALL A	
4	绿Green		HALL B	
5	蓝Blue		HALL C	
6	黄Yellow	UL1007/20AWG	PHASE U	
7	绿Green		PHASE V	
8	蓝Blue		PHASE W	

规格参数Technique Specification

型号Model	57HBL01A	57HBL02A	57HBL03A	57HBL04A
相数Number of phase	3			
极数 Number of pole	4 (可选8; Option for 8)			
额定电压Voltage	V 36v(可定制12v 24v 到115v); 36v(Option for 12v 24v up to 115vdc)			
空载转速No load speed	rpm 5200	rpm 5200	rpm 5300	rpm 5400
额定力矩Rated torque	Nm 0.14	Nm 0.28	Nm 0.43	Nm 0.49
额定转速Rated Speed	rpm 4000	rpm 4000	rpm 4000	rpm 4000
额定电流Rated Current	A 2.2	A 4.5	A 6.8	A 7.9
额定功率Rated Power	W 58.64	W 117.28	W 180.10	W 205.24
电机重量Weight	Kg 0.5	Kg 0.8	Kg 1.1	Kg 1.5
机身长度Length	mm 55	mm 75	mm 95	mm 115

机械尺寸Dimensions

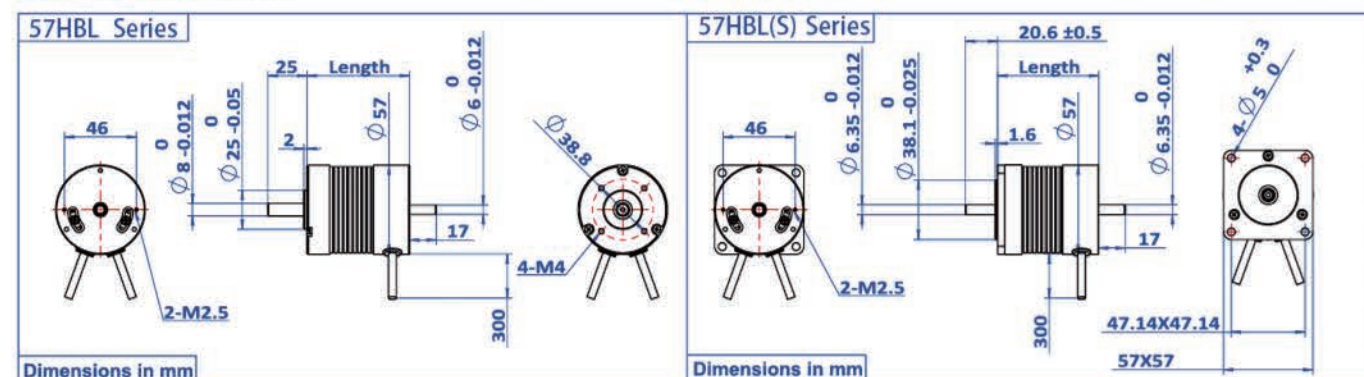

60BLS系列无刷直流电机

60BLS Series Brushless Dc Motor

常规性能General specification

项目Item	参数Specification
接线样式Winding type	Star
霍尔作用角度Hall effect angle	120° (电气角度electrical angle)
轴向跳动Shaft run out	0.025mm
径向间隙Radial play	0.025mm@450g
轴向间隙End play	0.025mm@450g
最大径向负载Max. radial force	100N@10mm from the flange
最大轴向负载Max. axial force	50N
绝缘等级Insulation class	Class B
介电强度Dielectric Strength	500VDC for one minute
绝缘电阻Insulation resistance	100MΩ Min.500VDC

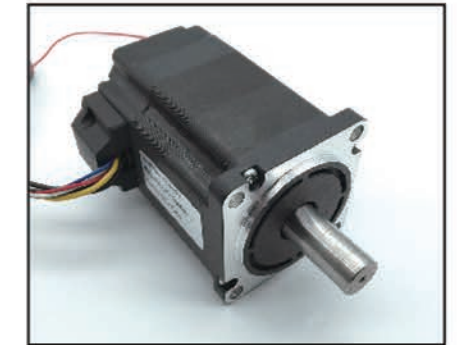

接线方式 Electric connection

顺序Lead No.	颜色Lead Color	线规Lead Gauge	功能Function	描述DESCRIPTION
1	红Red	UL1007/26AWG	VCC	霍尔电源SUPPLY VOLTAGE FOR HALL SENSORS
2	黑Black		GND	霍尔接地GROUND FOR HALL SENSORS
3	蓝Blue		HALL A	
4	绿Green		HALL B	
5	白White		HALL C	
6	红Red	UL1007/18AWG	PHASE U	
7	黄Yellow		PHASE V	
8	黑Black		PHASE W	

规格参数Technique Specification

型号Model	60BLS01A	60BLS02A	60BLS03A
相数Number of phase	3		
极数 Number of pole	8		
额定电压Voltage	V 24v(可定制12v 到60v); 24v(Option for 12v up to 60vdc)		
空载转速No load speed	rpm 4100	rpm 4100	rpm 4100
额定力矩Rated torque	Nm 0.3	Nm 0.6	Nm 1
额定转速Rated Speed	rpm 3000	rpm 3000	rpm 3000
额定电流Rated Current	A 3.6	A 7.5	A 12
额定功率Rated Power	W 94	W 188	W 315
电机重量Weight	Kg 0.9	Kg 1.2	Kg 1.6
机身长度Length	mm 78	mm 99	mm 120

机械尺寸Dimensions

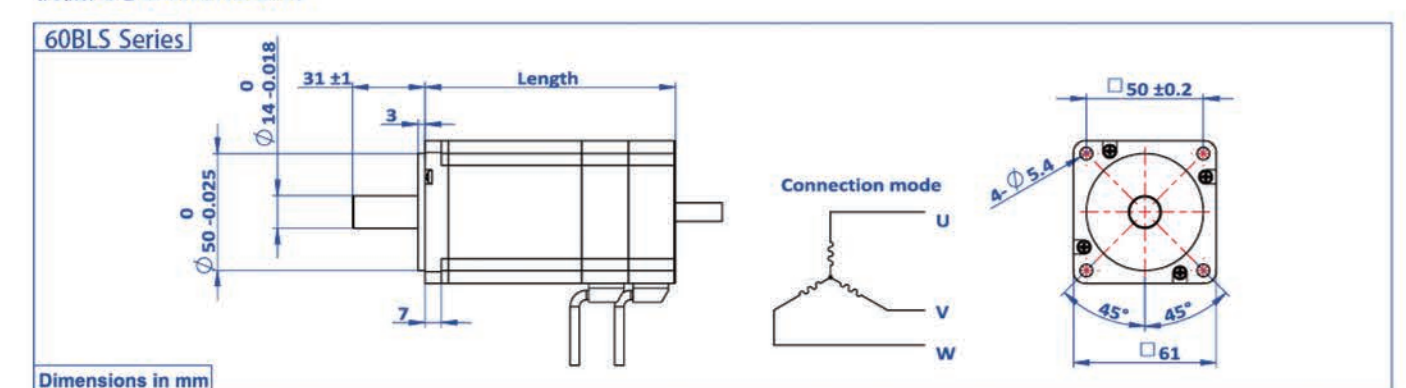

70BLS系列无刷直流电机

70BLS Series Brushless Dc Motor

常规性能General specification

项目Item	参数Specification
接线样式Winding type	Star
霍尔作用角度Hall effect angle	120° (电气角度electrical angle)
轴向跳动Shaft run out	0.05mm
径向间隙Radial play	0.025mm@450g
轴向间隙End play	0.025mm@450g
最大径向负载Max. radial force	100N@10mm from the flange
最大轴向负载Max. axial force	60N
绝缘等级Insulation class	Class B
介电强度Dielectric Strength	500VDC for one minute
绝缘电阻Insulation resistance	100MΩ Min.500VDC

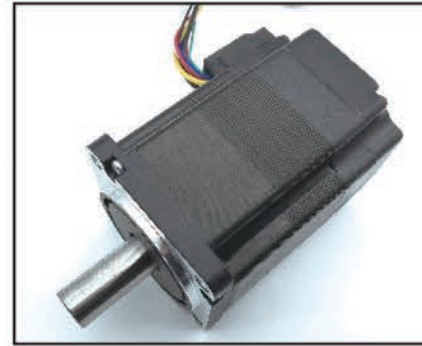

接线方式 Electric connection

顺序Lead No.	颜色Lead Color	线规Lead Gauge	功能Function	描述DESCRIPTION
1	红Red	UL1007/26AWG	VCC	霍尔电源SUPPLY VOLTAGE FOR HALL SENSORS
2	黑Black		GND	霍尔接地GROUND FOR HALL SENSORS
3	蓝Blue		HALL A	
4	绿Green	UL1007/16AWG	HALL B	
5	白White		HALL C	
6	红Red		PHASE U	
7	黄Yellow		PHASE V	
8	黑Black		PHASE W	

规格参数Technique Specification

型号Model	70BLS01A	70BLS02A	70BLS03A
相数Number of phase	3		
极数 Number of pole	8		
额定电压Voltage	V 48v(可定制12v 到60v); 48v(Option for 12v up to 60vdc)		
空载转速No load speed	rpm 3600	rpm 3600	rpm 3600
额定力矩Rated torque	Nm 0.5	Nm 1	Nm 1.5
额定转速Rated Speed	rpm 3000	rpm 3000	rpm 3000
额定电流Rated Current	A 4.3	A 8.7	A 12.9
额定功率Rated Power	W 157	W 314	W 471
电机重量Weight	Kg 1.7	Kg 2.2	Kg 2.8
机身长度Length	mm 86	mm 116	mm 136

机械尺寸Dimensions

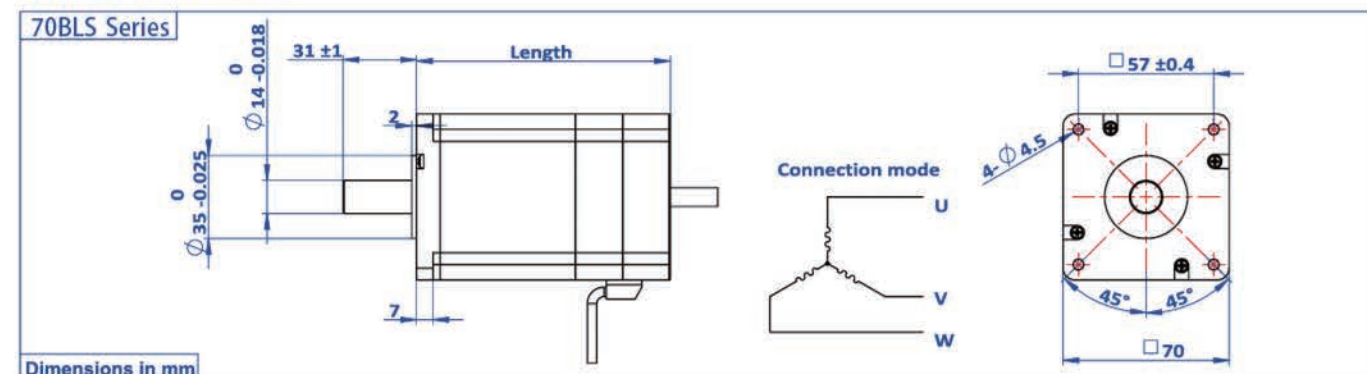

80BLS系列无刷直流电机

80BLS Series Brushless Dc Motor

常规性能General specification

项目Item	参数Specification
接线样式Winding type	Star
霍尔作用角度Hall effect angle	120° (电气角度electrical angle)
轴向跳动Shaft run out	0.025mm
径向间隙Radial play	0.06mm@450g
轴向间隙End play	0.08mm@450g
最大径向负载Max. radial force	200N@10mm from the flange
最大轴向负载Max. axial force	60N
绝缘等级Insulation class	Class B
介电强度Dielectric Strength	500VDC for one minute
绝缘电阻Insulation resistance	100MΩ Min.500VDC

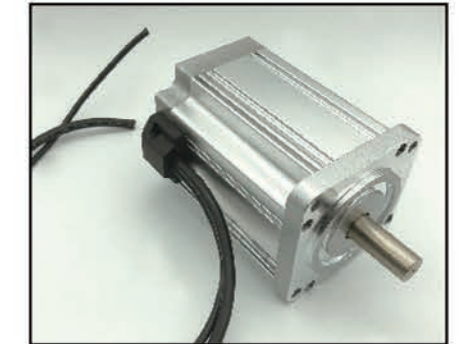

接线方式 Electric connection

顺序Lead No.	颜色Lead Color	线规Lead Gauge	功能Function	描述DESCRIPTION
1	红Red	UL1007/26AWG	VCC	霍尔电源SUPPLY VOLTAGE FOR HALL SENSORS
2	黑Black		GND	霍尔接地GROUND FOR HALL SENSORS
3	蓝Blue		HALL A	
4	绿Green	UL1007/14AWG	HALL B	
5	白White		HALL C	
6	红Red		PHASE U	
7	黄Yellow		PHASE V	
8	黑Black		PHASE W	

规格参数Technique Specification

型号Model	80BLS01A	80BLS02A	80BLS03A	80BLS04A
相数Number of phase	3			
极数 Number of pole	8			
额定电压Voltage	V 24v(可定制12v 到230v); 24v(Option for 12v up to 230vdc)			
空载转速No load speed	rpm 4200	rpm 4200	rpm 4200	rpm 4200
额定力矩Rated torque	Nm 0.3	Nm 0.65	Nm 1	Nm 1.3
额定转速Rated Speed	rpm 3000	rpm 3000	rpm 3000	rpm 3000
额定电流Rated Current	A 6.5	A 12.5	A 18	A 20.5
额定功率Rated Power	W 94	W 200	W 315	W 410
电机重量Weight	Kg 1.6	Kg 2.2	Kg 3	Kg 3.8
机身长度Length	mm 85	mm 105	mm 115	mm 145

机械尺寸Dimensions

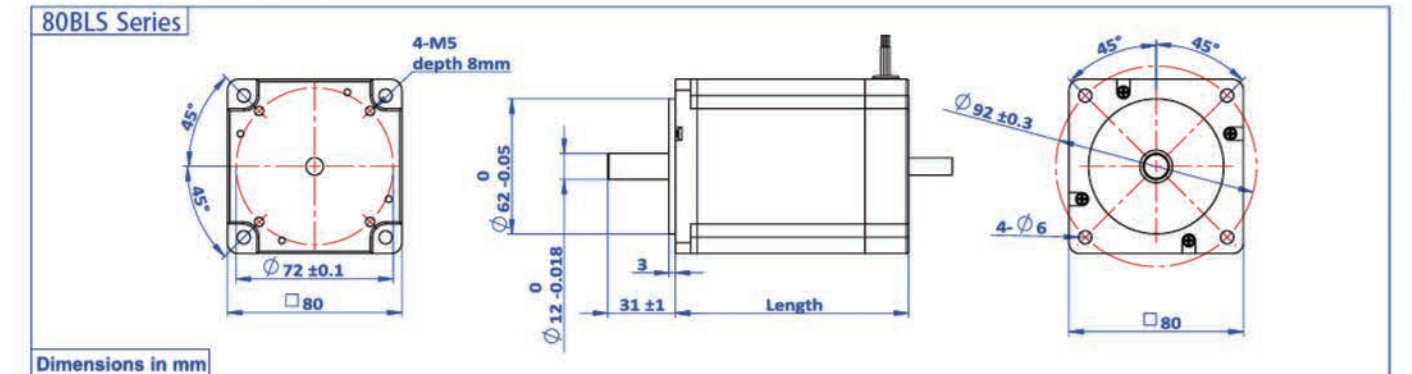

80RBL系列无刷直流电机

80RBL Series Round Type 80mm Brushless Dc Motor

常规性能General specification

项目Item	参数Specification
接线样式Winding type	Star
霍尔作用角度Hall effect angle	120° (电气角度electrical angle)
轴向跳动Shaft run out	0.025mm
径向间隙Radial play	0.06mm@450g
轴向间隙End play	0.08mm@450g
最大径向负载Max. radial force	200N@10mm from the flange
最大轴向负载Max. axial force	60N
绝缘等级Insulation class	Class B
介电强度Dielectric Strength	500VDC for one minute
绝缘电阻Insulation resistance	100MΩ Min.500VDC



接线方式 Electric connection

顺序Lead No.	颜色Lead Color	线规Lead Gauge	功能Function	描述DESCRIPTION
1	红Red	UL1007/26AWG	VCC	霍尔电源SUPPLY VOLTAGE FOR HALL SENSORS
2	黑Black		GND	霍尔接地GROUND FOR HALL SENSORS
3	蓝Blue		HALL A	
4	绿Green		HALL B	
5	白White		HALL C	
6	红Red	UL1007/14AWG	PHASE U	
7	黄Yellow		PHASE V	
8	黑Black		PHASE W	

规格参数Technique Specification

型号Model	80RBL01A	80RBL02A	80RBL03A	80RBL04A	80RBL05A
相数Number of phase	3				
极数 Number of pole	8				
额定电压Voltage	V 24v(可定制12v 到230v); 24v(Option for 12v up to 230vdc)				
空载转速No load speed	rpm 4000	4000	4000	4000	4000
额定力矩Rated torque	Nm 0.4	0.8	1.2	1.4	1.8
额定转速Rated Speed	rpm 3000	3000	3000	3000	3000
额定电流Rated Current	A 7.5	15	22.5	26	33.5
额定功率Rated Power	W 126	252	378	442	568
电机重量Weight	Kg 1.2	1.7	2.3	2.5	2.8
机身长度Length	mm 60	80	100	115	135

机械尺寸Dimensions

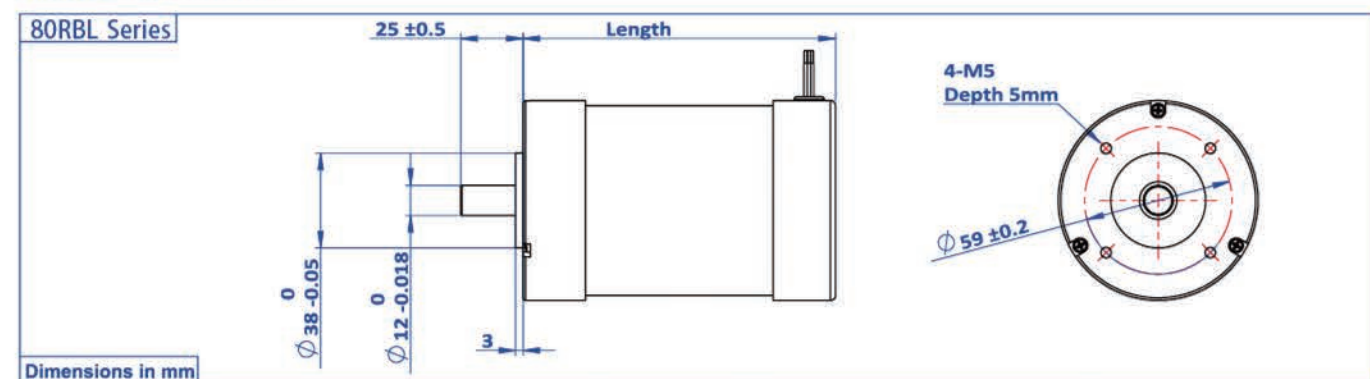

86BLS系列方形无刷直流电机

86BLS Series Square Type Brushless Dc Motor

常规性能General specification

项目Item	参数Specification
接线样式Winding type	Star
霍尔作用角度Hall effect angle	120° (电气角度electrical angle)
轴向跳动Shaft run out	0.025mm
径向间隙Radial play	0.06mm@450g
轴向间隙End play	0.08mm@450g
最大径向负载Max. radial force	220N@10mm from the flange
最大轴向负载Max. axial force	60N
绝缘等级Insulation class	Class B
介电强度Dielectric Strength	500VDC for one minute
绝缘电阻Insulation resistance	100MΩ Min.500VDC



接线方式 Electric connection

顺序Lead No.	颜色Lead Color	线规Lead Gauge	功能Function	描述DESCRIPTION
1	红Red	UL1007/26AWG	VCC	霍尔电源SUPPLY VOLTAGE FOR HALL SENSORS
2	黑Black		GND	霍尔接地GROUND FOR HALL SENSORS
3	蓝Blue		HALL A	
4	绿Green		HALL B	
5	白White		HALL C	
6	红Red	UL1007/14AWG	PHASE U	
7	黄Yellow		PHASE V	
8	黑Black		PHASE W	

规格参数Technique Specification

型号Model	86BLS01A	86BLS02A	86BLS03A
相数Number of phase	3		
极数 Number of pole	8		
额定电压Voltage	V 48v(可定制12v 2v到230v); 48v(Option for 12v 24v up to 230vdc)		
空载转速No load speed	rpm 3600	3600	3600
额定力矩Rated torque	Nm 1.0	1.8	2.5
额定转速Rated Speed	rpm 3000	3000	3000
额定电流Rated Current	A 8.6	14.8	20
额定功率Rated Power	W 314	565	785
电机重量Weight	Kg 2.2	3.2	4.2
机身长度Length	mm 80	105	130

机械尺寸Dimensions

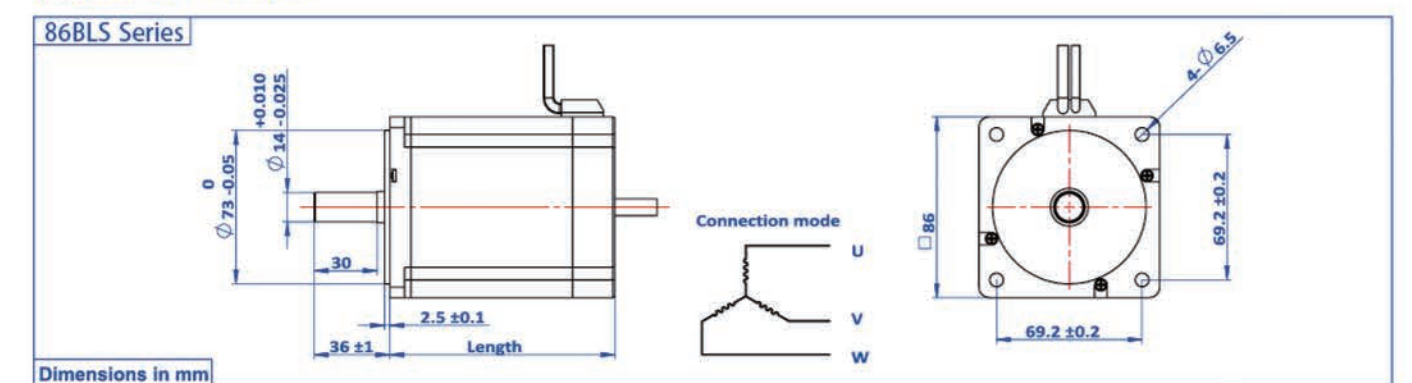

86RBL系列圆形无刷直流电机

86RBL Series Round Type 86mm Brushless Dc Motor

常规性能General specification

项目Item	参数Specification
接线样式Winding type	Star
霍尔作用角度Hall effect angle	120° (电气角度electrical angle)
轴向跳动Shaft run out	0.025mm
径向间隙Radial play	0.06mm@450g
轴向间隙End play	0.08mm@450g
最大径向负载Max. radial force	220N@10mm from the flange
最大轴向负载Max. axial force	60N
绝缘等级Insulation class	Class B
介电强度Dielectric Strength	500VDC for one minute
绝缘电阻Insulation resistance	100MΩ Min.500VDC



接线方式 Electric connection

顺序Lead No.	颜色Lead Color	线规Lead Gauge	功能Function	描述DESCRIPTION
1	红Red	UL1007/26AWG	VCC	霍尔电源SUPPLY VOLTAGE FOR HALL SENSORS
2	黑Black		GND	霍尔接地GROUND FOR HALL SENSORS
3	蓝Blue		HALL A	
4	绿Green		HALL B	
5	白 White		HALL C	
6	红Red	UL1007/14AWG	PHASE U	
7	黄Yellow		PHASE V	
8	黑Black		PHASE W	

规格参数Technique Specification

型号Model	86RBL01A	86RBL02A	86RBL03A
相数Number of phase		3	
极数 Number of pole		8	
额定电压Voltage	V	48v(可定制12v 24v到230v);48v(Option for 12v 24v up to 230vdc)	
空载转速No load speed	rpm	3600	3600
额定力矩Rated torque	Nm	1.0	1.8
额定转速Rated Speed	rpm	3000	3000
额定电流Rated Current	A	8.6	14.8
额定功率Rated Power	W	314	565
电机重量Weight	Kg	2.2	3.2
机身长度Length	mm	80	105

机械尺寸Dimensions

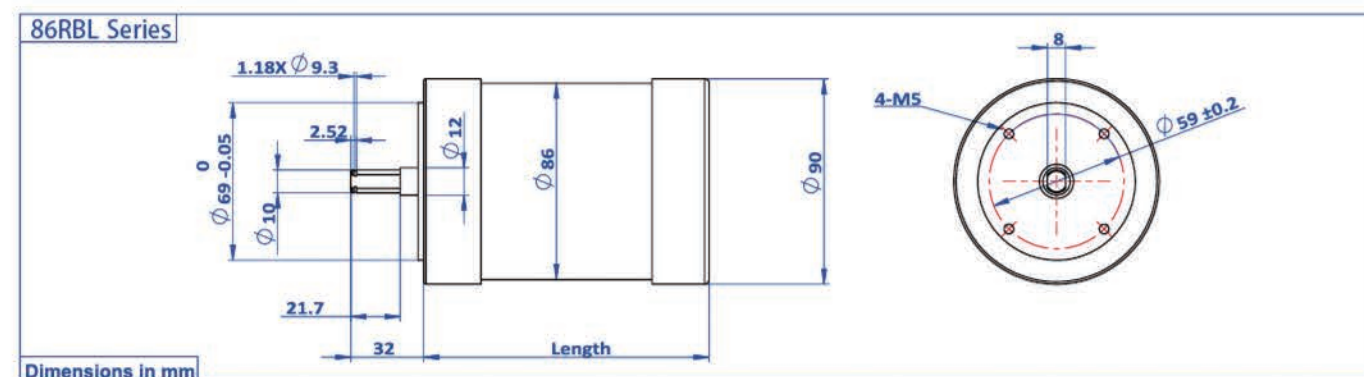

110BLS系列无刷直流电机

110BLS Series Brushless Dc Motor

常规性能General specification

项目Item	参数Specification
接线样式Winding type	Star
霍尔作用角度Hall effect angle	120° (电气角度electrical angle)
轴向跳动Shaft run out	0.025mm
径向间隙Radial play	0.06mm@450g
轴向间隙End play	0.08mm@450g
最大径向负载Max. radial force	300N@10mm from the flange
最大轴向负载Max. axial force	60N
绝缘等级Insulation class	Class B
介电强度Dielectric Strength	500VDC for one minute
绝缘电阻Insulation resistance	100MΩ Min.500VDC

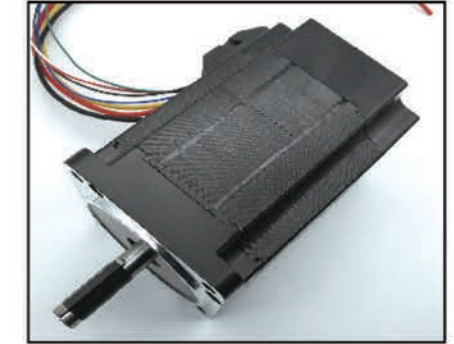

接线方式 Electric connection

顺序Lead No.	颜色Lead Color	线规Lead Gauge	功能Function	描述DESCRIPTION
1	红Red	UL1007/26AWG	VCC	霍尔电源SUPPLY VOLTAGE FOR HALL SENSORS
2	黑Black		GND	霍尔接地GROUND FOR HALL SENSORS
3	蓝Blue		HALL A	
4	绿Green		HALL B	
5	白 White		HALL C	
6	红Red	UL1007/12AWG	PHASE U	
7	黄Yellow		PHASE V	
8	黑Black		PHASE W	

规格参数Technique Specification

型号Model	110BLS01A	110BLS02A	110BLS03A	110BLS04A
相数Number of phase			3	
极数 Number of pole			8	
额定电压Voltage	V	48v(可定制12v 到300v); 48v(Option for 12v up to 300vdc)		
空载转速No load speed	rpm	2830	2830	2770
额定力矩Rated torque	Nm	1.65	3.3	5
额定转速Rated Speed	rpm	2530	2530	2370
额定电流Rated Current	A	13	23	32
额定功率Rated Power	W	440	875	1240
电机重量Weight	Kg	4.2	5.5	6.8
机身长度Length	mm	93	123	153

机械尺寸Dimensions

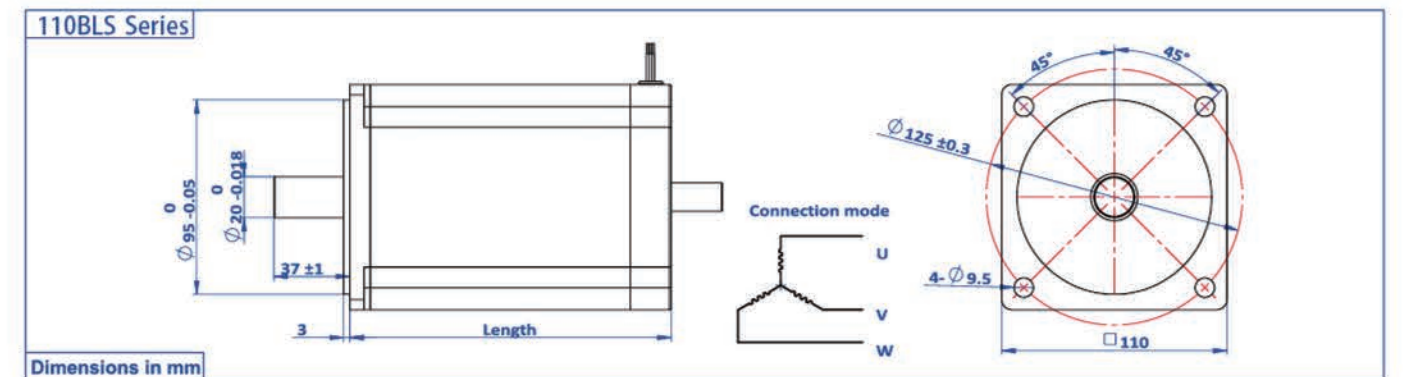

28JXE10K.28BL 系列无刷直行星齿轮减速电机
28JXE10K.28BL Brushless Dc Planetary Gear Motor

图纸 Drawing

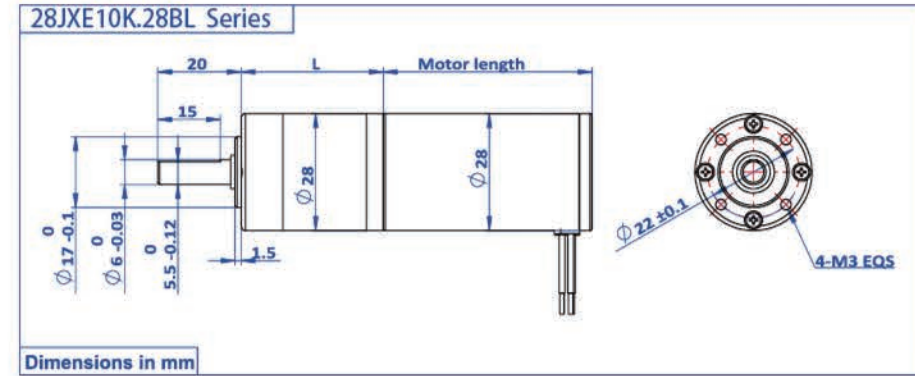

28BL电机规格参数Motor Technique Specification

型号Model	28BL01A	28BL02A	28BL03A
相数Number of phase	3		
极数 Number of pole	4		
额定电压Voltage	V 24v(可定制12v 到48v); 24v (Option for 12v up to 48vdc)		
空载转速No load speed	rpm 8000	8000	9000
额定力矩Rated torque	mNm 10	15	20
额定转速Rated Speed	rpm 6000	6000	8000
额定电流Rated Current	A 1.8	2.6	3.6
额定功率Rated Power	W 7	10	18
电机重量Weight	g 82	105	128
机身长度Length	mm 39	49	59

行星齿轮箱主要性能参数 Planetary Gearbox Specifications 型号 Gearbox Model:28JXE10K

内齿圈材料 Ring material	E 型:金属 Metal	
输出轴轴承形式 Bearing at output	含油轴承Sleeve bearings	滚动轴承Ball bearings
最大允许径向负载(离法兰10mm处) Max. Radial load (10mm from flange)	≤16N	≤20N
最大允许轴向负载Max. shaft axial load	≤10N	≤10N
径向间隙 (测量点尽量接近法兰) Radial play of shaft (near to flange)	≤0.08mm	≤0.08mm
轴向间隙 Axial play of shaft	≤0.3mm	≤0.3mm
背隙 (无负载时) Backlash at no-load)	≤2.5°	
输出轴最大承受压入力 Shaft press fit force max	≤60N	

减速比 Reduction ratio	额定允许负载 Rated tolerance torque	瞬间允许负载 Max momentary tolerance torque	效率 Efficiency	L (mm)	重量(g) Weight(g)
1/3.7 1/5.2	0.1N.m	0.3N.m	90%	22.5±0.5	68
1/14 1/19 1/27	0.4N.m	1.2N.m	81%	32.0±0.5	98
1/51 1/71 1/100 1/139	0.8N.m	2.4N.m	73%	40.3±0.5	129
1/189 1/264 1/369 1/516 1/720	1.0N.m	3.0N.m	66%	48.6±0.5	156

36JXE30K.36BL 系列无刷直行星齿轮减速电机
36JXE30K.36BL Brushless Dc Planetary Gear Motor

图纸 Drawing

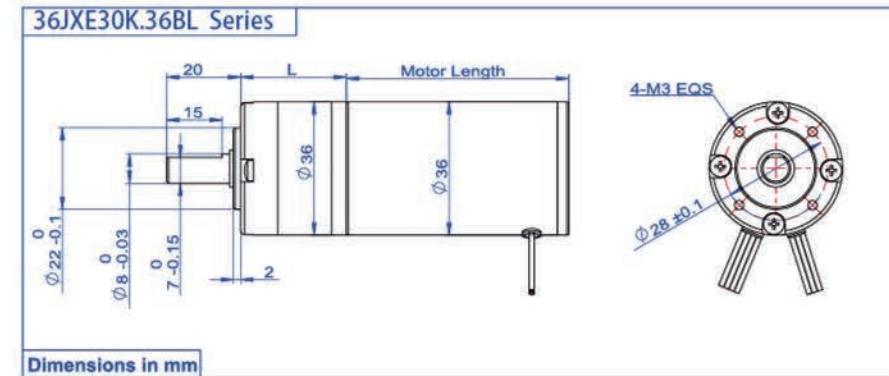

36BL电机规格参数Motor Technique Specification

型号Model	36BL01A	36BL02A	36BL03A
相数Number of phase	3		
极数 Number of pole	4		
额定电压Voltage	V 24v(可定制12v 到48v); 24v(Option for 12v up to 48vdc)		
空载转速No load speed	rpm 6200	8000	9500
额定力矩Rated torque	mNm 36	60	75
额定转速Rated Speed	rpm 4800	6000	8000
额定电流Rated Current	A 2	3.5	4.5
额定功率Rated Power	W 18	40	63
电机重量Weight	g 185	210	250
机身长度Length	mm 45	55	65

行星齿轮箱主要性能参数 Planetary Gearbox Specifications 型号 Gearbox Model:36JXE30K

内齿圈材料 Ring material	E 型:金属 Metal	
输出轴轴承形式 Bearing at output	滚动轴承Ball bearings	
最大允许径向负载(离法兰10mm处) Max. Radial load (10mm from flange)	≤50N	
最大允许轴向负载Max. shaft axial load	≤30N	
径向间隙 (测量点尽量接近法兰) Radial play of shaft (near to flange)	≤0.07mm	
轴向间隙 Axial play of shaft	≤0.3mm	
背隙 (无负载时) Backlash at no-load)	≤2.5°	
输出轴最大承受压入力 Shaft press fit force max	≤120N	

减速比 Reduction ratio	额定允许负载 Rated tolerance torque	瞬间允许负载 Max momentary tolerance torque	效率 Efficiency	L (mm)	重量(g) Weight(g)
1/3.7 1/5.2	0.3N.m	1.0N.m	90%	26.5±0.5	168
1/14 1/19 1/27	1.2N.m	3.5N.m	81%	33.6±0.5	207
1/51 1/71 1/100 1/139	2.5N.m	7.5N.m	73%	40.5±0.5	248
1/182 1/219 1/254 1/306 1/354 1/427 1/495 1/596	3.0N.m	9.0N.m	66%	47.4±0.5	296

42JXE100K.42RBL 系列无刷直行星齿轮减速电机
42JXE100K.42RBL Brushless Dc Planetary Gear Motor

图纸 Drawing

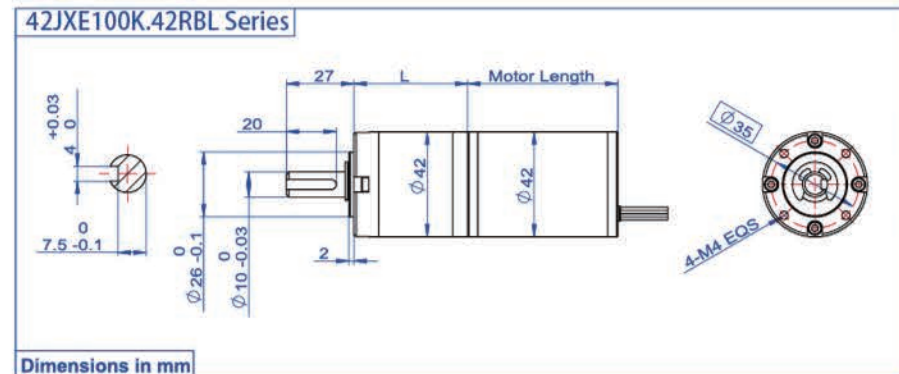

42RBL电机规格参数Motor Technique Specification

型号Model		42RBL01A	42RBL02A	42RBL03A	42RBL04A
相数Number of phase		3			
极数 Number of pole		8			
额定电压Voltage	V	24v(可定制12v 到48v); 24v(Option for 12v up to 48vdc)			
空载转速No load speed	rpm	5200	5200	5200	5200
额定力矩Rated torque	Nm	0.018	0.08	0.15	0.25
额定转速Rated Speed	rpm	4000	4000	4000	4000
额定电流Rated Current	A	0.5	2	4.2	9.5
额定功率Rated Power	W	7.6	33.5	62	104
电机重量Weight	Kg	0.25	0.4	0.7	0.75
机身长度Length	mm	30	60	85	93

42JXE100K.42BLS 系列无刷直行星齿轮减速电机
42JXE100K.42BLS Brushless Dc Planetary Gear Motor

图纸 Drawing

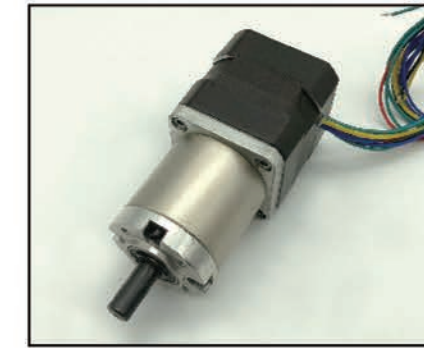
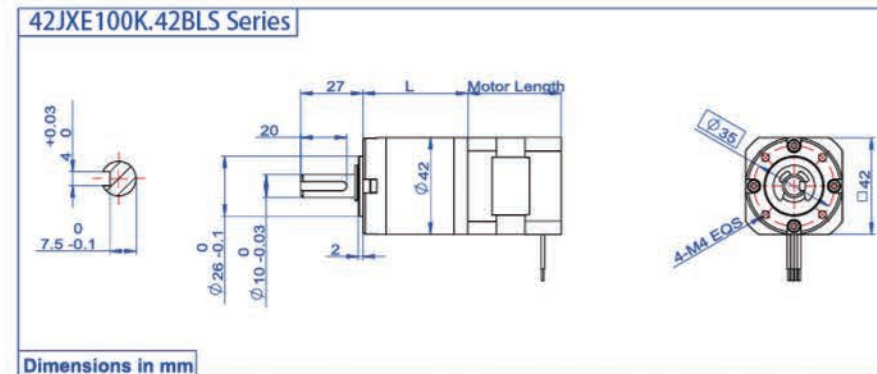

42BLS电机规格参数Motor Technique Specification

型号Model		42BLS01A	42BLS02A	42BLS03A	42BLS04A
相数Number of phase		3			
极数 Number of pole		8			
额定电压Voltage	V	24v(可定制12v 到48v); 24v(Option for 12v up to 48vdc)			
空载转速No load speed	rpm	5000	5000	5000	5000
额定力矩Rated torque	Nm	0.063	0.125	0.185	0.25
额定转速Rated Speed	rpm	4000	4000	4000	4000
额定电流Rated Current	A	1.7	3.5	4.6	6
额定功率Rated Power	W	26	52	77	104
电机重量Weight	Kg	0.3	0.45	0.65	0.75
机身长度Length	mm	41	61	81	100

行星齿轮箱主要性能参数 Planetary Gearbox Specifications 型号 Gearbox Model: 42JXE100K

内齿圈材料 Ring material	E 型:金属 Metal
输出轴承形式 Bearing at output	滚动轴承Ball bearings
最大允许径向负载(离法兰10mm处) Max. Radial load (10mm from flange)	≤80N
最大允许轴向负载Max. shaft axial load	≤30N
径向间隙(测量点尽量接近法兰) Radial play of shaft (near to flange)	≤0.06mm
轴向间隙 Axial play of shaft	≤0.3mm
背隙(无负载时) Backlash at no-load	≤2.5°
输出轴最大承受压入力 Shaft press fit force max	≤150N

减速比 Reduction ratio	额定允许负载 Rated tolerance torque	瞬间允许负载 Max momentary tolerance torque	效率 Efficiency	L (mm)	重量(g) Weight(g)
1/3.7 1/5.2	1.0N.m	3.0N.m	90%	31.5±0.5	244
1/14 1/19 1/27	4.0N.m	12N.m	81%	42.1±0.5	314
1/51 1/71 1/100 1/139	8.0N.m	25N.m	73%	52.5±0.5	433
1/182 1/219 1/254 1/306 1/354 1/427 1/495 1/596	10N.m	30N.m	66%	62.9±0.5	519

行星齿轮箱主要性能参数 Planetary Gearbox Specifications 型号 Gearbox Model: 42JXE100K

内齿圈材料 Ring material	E 型:金属 Metal
输出轴承形式 Bearing at output	滚动轴承Ball bearings
最大允许径向负载(离法兰10mm处) Max. Radial load (10mm from flange)	≤80N
最大允许轴向负载Max. shaft axial load	≤30N
径向间隙(测量点尽量接近法兰) Radial play of shaft (near to flange)	≤0.06mm
轴向间隙 Axial play of shaft	≤0.3mm
背隙(无负载时) Backlash at no-load	≤2.5°
输出轴最大承受压入力 Shaft press fit force max	≤150N

减速比 Reduction ratio	额定允许负载 Rated tolerance torque	瞬间允许负载 Max momentary tolerance torque	效率 Efficiency	L (mm)	重量(g) Weight(g)
1/3.7 1/5.2	1.0N.m	3.0N.m	90%	31.5±0.5	244
1/14 1/19 1/27	4.0N.m	12N.m	81%	42.1±0.5	314
1/51 1/71 1/100 1/139	8.0N.m	25N.m	73%	52.5±0.5	433
1/182 1/219 1/254 1/306 1/354 1/427 1/495 1/596	10N.m	30N.m	66%	62.9±0.5	519

56JXE300K.57BL 系列无刷直流行星齿轮减速电机
56JXE300K.57BL Brushless Dc Planetary Gear Motor

图纸 Drawing

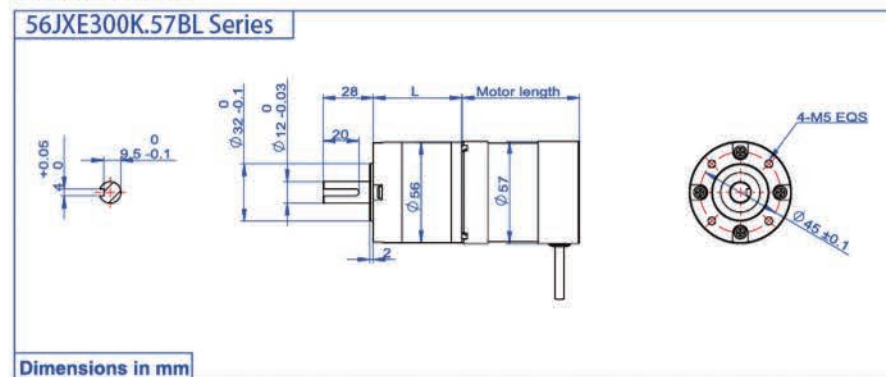

56JXE300K.57HBL 系列无刷直流行星齿轮减速电机
56JXE300K.57HBL Brushless Dc Planetary Gear Motor

图纸 Drawing

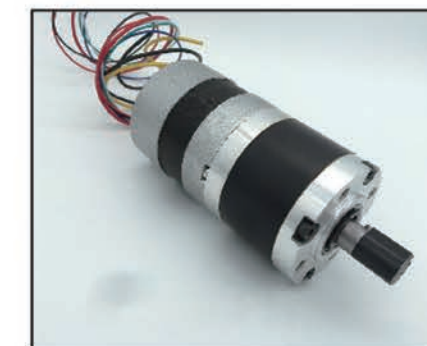
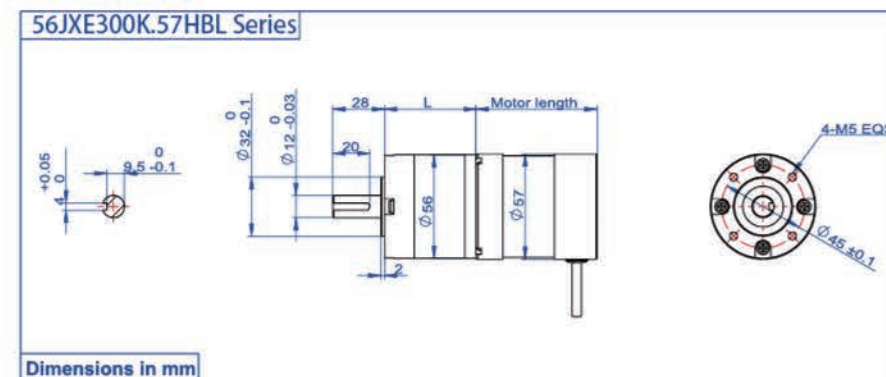

57BL电机规格参数Motor Technique Specification

型号Model	57BL(S)005A	57BL(S)01A	57BL(S)02A	57BL(S)03A	57BL(S)04A
相数Number of phase	3				
极数 Number of pole	4 (可选8; Option for 8)				
额定电压Voltage	V 36v(可定制12v 24v到115v); 36v(Option for 12v 24v up to 115vdc)				
空载转速No load speed	rpm	5200	5200	5200	5300
额定力矩Rated torque	Nm	0.055	0.11	0.22	0.32
额定转速Rated Speed	rpm	4000	4000	4000	4000
额定电流Rated Current	A	1	1.8	3.2	4.7
额定功率Rated Power	W	23.04	46.07	92.15	134.03
电机重量Weight	Kg	0.28	0.5	0.75	1
机身长度Length	mm	45	55	75	95

57HBL电机规格参数Motor Technique Specification

型号Model	57HBL01A	57HBL02A	57HBL03A	57HBL04A
相数Number of phase	3			
极数 Number of pole	4 (可选8; Option for 8)			
额定电压Voltage	V 36v(可定制12v 24v 到115v); 36v(Option for 12v24v up to 115vdc)			
空载转速No load speed	rpm	5200	5200	5300
额定力矩Rated torque	Nm	0.14	0.28	0.43
额定转速Rated Speed	rpm	4000	4000	4000
额定电流Rated Current	A	2.2	4.5	6.8
额定功率Rated Power	W	58.64	117.28	180.10
电机重量Weight	Kg	0.5	0.8	1.1
机身长度Length	mm	55	75	95

行星齿轮箱主要性能参数 Planetary Gearbox Specifications 型号 Gearbox Model: 56(60)JXE300K

内齿圈材料 Ring material	E 型:金属 Metal
输出轴轴承形式 Bearing at output	滚动轴承Ball bearings
最大允许径向负载(离法兰10mm处) Max. Radial load (10mm from flange)	≤250N
最大允许轴向负载Max. shaft axial load	≤100N
径向间隙 (测量点尽量接近法兰) Radial play of shaft (near to flange)	≤0.08mm
轴向间隙 Axial play of shaft	≤0.4mm
背隙 (无负载时) Backlash at no-load	≤2.5°
输出轴最大承受压入力 Shaft press fit force max	≤300N

行星齿轮箱主要性能参数 Planetary Gearbox Specifications 型号 Gearbox Model: 56(60)JXE300K

内齿圈材料 Ring material	E 型:金属 Metal
输出轴轴承形式 Bearing at output	滚动轴承Ball bearings
最大允许径向负载(离法兰10mm处) Max. Radial load (10mm from flange)	≤250N
最大允许轴向负载Max. shaft axial load	≤100N
径向间隙 (测量点尽量接近法兰) Radial play of shaft (near to flange)	≤0.08mm
轴向间隙 Axial play of shaft	≤0.4mm
背隙 (无负载时) Backlash at no-load	≤2.5°
输出轴最大承受压入力 Shaft press fit force max	≤300N

减速比 Reduction ratio	额定允许负载 Rated tolerance torque	瞬间允许负载 Max momentary tolerance torque	效率 Efficiency	L (mm)	重量 (g) Weight(g)
1/3.6 1/4.3	3.0N.m	9.0N.m	90%	37.8±0.5	489
1/13 1/15 1/18 1/23	12.0N.m	36N.m	81%	49.5±0.5	681
1/47 1/55 1/65 1/77 1/96 1/121	24.0N.m	72N.m	73%	60.8±0.5	871
1/154 1/187 1/220 1/260 1/307 1/409 1/514 1/645	30N.m	90N.m	66%	71.9±0.5	1066

减速比 Reduction ratio	额定允许负载 Rated tolerance torque	瞬间允许负载 Max momentary tolerance torque	效率 Efficiency	L (mm)	重量 (g) Weight(g)
1/3.6 1/4.3	3.0N.m	9.0N.m	90%	37.8±0.5	489
1/13 1/15 1/18 1/23	12.0N.m	36N.m	81%	49.5±0.5	681
1/47 1/55 1/65 1/77 1/96 1/121	24.0N.m	72N.m	73%	60.8±0.5	871
1/154 1/187 1/220 1/260 1/307 1/409 1/514 1/645	30N.m	90N.m	66%	71.9±0.5	1066

56JXE450K.57HBL 系列无刷直流行星齿轮减速电机 56JXE450K.57HBL Brushless Dc Planetary Gear Motor

图纸 Drawing

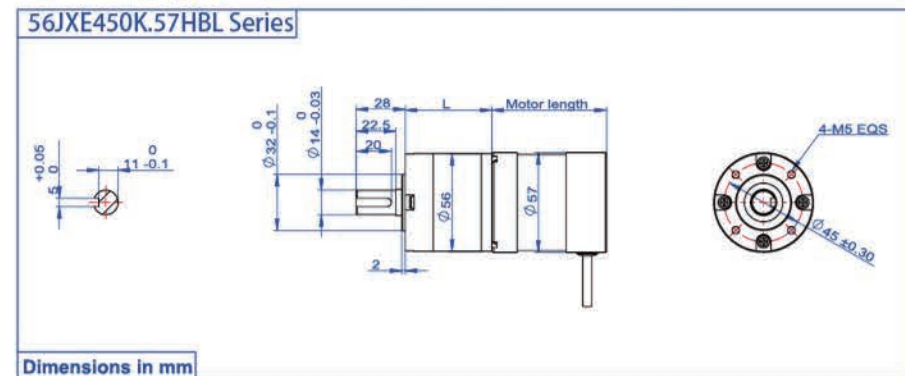

57HBL规格参数Technique Specification

型号Model	57HBL01A	57HBL02A	57HBL03A	57HBL04A
相数Number of phase	3			
极数 Number of pole	4 (可选8; Option for 8)			
额定电压Voltage	V 36v(可定制12v 24v 到115v); 36v(Option for 12v24v up to 115vdc)			
空载转速No load speed	rpm 5200	rpm 5200	rpm 5300	rpm 5400
额定力矩Rated torque	Nm 0.14	Nm 0.28	Nm 0.43	Nm 0.54
额定转速Rated Speed	rpm 4000	rpm 4000	rpm 4000	rpm 4000
额定电流Rated Current	A 2.2	A 4.5	A 6.8	A 9.0
额定功率Rated Power	W 58.64	W 117.28	W 180.10	W 205.24
电机重量Weight	Kg 0.5	Kg 0.8	Kg 1.1	Kg 1.5
机身长度Length	mm 55	mm 75	mm 95	mm 115

行星齿轮箱主要性能参数 Planetary Gearbox Specifications 型号 Gearbox Model: 56JXE450K

内齿圈材料 Ring material	E 型:金属 Metal
输出轴轴承形式 Bearing at output	滚动轴承Ball bearings
最大允许径向负载(离法兰10mm处) Max. Radial load (10mm from flange)	≤400N
最大允许轴向负载Max. shaft axial load	≤120N
径向间隙 (测量点尽量接近法兰) Radial play of shaft (near to flange)	≤0.08mm
轴向间隙 Axial play of shaft	≤0.4mm
背隙 (无负载时) Backlash at no-load	≤1.5°
输出轴最大承受压入力 Shaft press fit force max	≤300N

减速比 Reduction ratio	额定允许负载 Rated tolerance torque	瞬间允许负载 Max momentary tolerance torque	效率 Efficiency	L (mm)	重量 (g) Weight(g)
1/3.6 1/4.25 1/5.33	4 N.m	12 N.m	90%	40.3±0.5	520
1/13 1/15 1/18 1/23 1/28	18 N.m	36 N.m	81%	53.8±0.5	710
1/43 1/52 1/61 1/72 1/96 1/121	36 N.m	72 N.m	73%	67.2±0.5	900
1/154 1/187 1/220 1/260 1/307	45 N.m	90N.m	66%	80.6±0.5	1100
1/409 1/514 1/645 1/809					

60JXE450K.80RBL 系列无刷直流行星齿轮减速电机 60JXE450K.80RBL Brushless Dc Planetary Gear Motor

图纸 Drawing

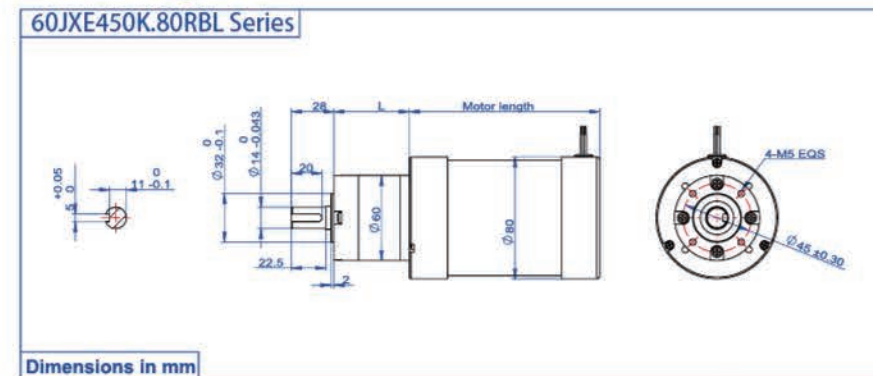

80RBL电机规格参数Motor Technique Specification

型号Model	80RBL01A	80RBL02A	80RBL03A	80RBL04A	80RBL05A
相数Number of phase	3				
极数 Number of pole	8				
额定电压Voltage	V 24v(可定制12v 到230v); 24v(Option for 12v up to 230vdc)				
空载转速No load speed	rpm 4000	rpm 4000	rpm 4000	rpm 4000	rpm 4000
额定力矩Rated torque	Nm 0.4	Nm 0.8	Nm 1.2	Nm 1.4	Nm 1.8
额定转速Rated Speed	rpm 3000	rpm 3000	rpm 3000	rpm 3000	rpm 3000
额定电流Rated Current	A 7.5	A 15	A 22.5	A 26	A 33.5
额定功率Rated Power	W 126	W 252	W 378	W 442	W 568
电机重量Weight	Kg 1.2	Kg 1.7	Kg 2.3	Kg 2.5	Kg 2.8
机身长度Length	mm 60	mm 80	mm 100	mm 115	mm 135

行星齿轮箱主要性能参数 Planetary Gearbox Specifications 型号 Gearbox Model: 60JXE450K

内齿圈材料 Ring material	E 型:金属 Metal
输出轴轴承形式 Bearing at output	滚动轴承Ball bearings
最大允许径向负载(离法兰10mm处) Max. Radial load (10mm from flange)	≤400N
最大允许轴向负载Max. shaft axial load	≤120N
径向间隙 (测量点尽量接近法兰) Radial play of shaft (near to flange)	≤0.08mm
轴向间隙 Axial play of shaft	≤0.4mm
背隙 (无负载时) Backlash at no-load	≤1.5°
输出轴最大承受压入力 Shaft press fit force max	≤300N

减速比 Reduction ratio	额定允许负载 Rated tolerance torque	瞬间允许负载 Max momentary tolerance torque	效率 Efficiency	L (mm)	重量 (g) Weight(g)
1/3.6 1/4.25 1/5.33	4 N.m	12 N.m	90%	40.3±0.5	520
1/13 1/15 1/18 1/23 1/28	18 N.m	36 N.m	81%	53.8±0.5	710
1/43 1/52 1/61 1/72 1/96 1/121	36 N.m	72 N.m	73%	67.2±0.5	900
1/154 1/187 1/220 1/260 1/307	45 N.m	90N.m	66%	80.6±0.5	1100
1/409 1/514 1/645 1/809					

60JXE450K.86RBL 系列无刷直行星齿轮减速电机
60JXE450K.86RBL Brushless Dc Planetary Gear Motor

图纸 Drawing

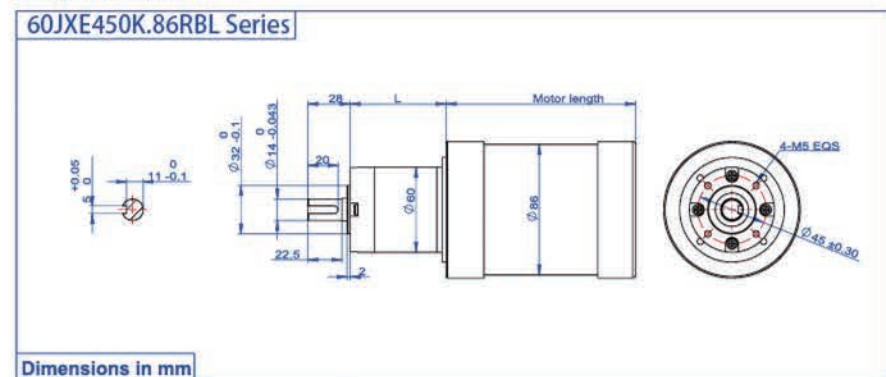

82PN.86BL 系列无刷直行星齿轮减速电机
82PN.86BL Brushless Dc Planetary Gear Motor

图纸 Drawing

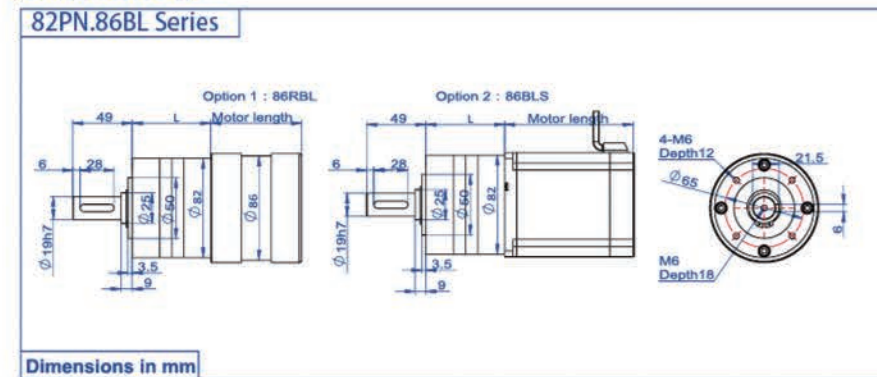

86RBL电机规格参数Motor Technique Specification

型号Model		86RBL01A	86RBL02A	86RBL03A
相数Number of phase			3	
极数 Number of pole			8	
额定电压Voltage	V	48v(可定制12v 24v到230v);48v(Option for 12v 24v up to 230vdc)		
空载转速No load speed	rpm	3600	3600	3600
额定力矩Rated torque	Nm	1.0	1.8	2.5
额定转速Rated Speed	rpm	3000	3000	3000
额定电流Rated Current	A	8.6	14.8	20
额定功率Rated Power	W	314	565	785
电机重量Weight	Kg	2.2	3.2	4.2
机身长度Length	mm	80	105	130

86RBL电机规格参数Motor Technique Specification

型号Model		86BL01A	86BL02A	86BL03A
相数Number of phase			3	
极数 Number of pole			8	
额定电压Voltage	V	48v(可定制12v 24v到230v);48v(Option for 12v 24v up to 230vdc)		
空载转速No load speed	rpm	3600	3600	3600
额定力矩Rated torque	Nm	1.0	1.8	2.5
额定转速Rated Speed	rpm	3000	3000	3000
额定电流Rated Current	A	8.6	14.8	20
额定功率Rated Power	W	314	565	785
电机重量Weight	Kg	2.2	3.2	4.2
机身长度Length	mm	80	105	130

行星齿轮箱主要性能参数 Planetary Gearbox Specifications 型号 Gearbox Model: 60JXE450K

内齿圈材料 Ring material	E 型-金属 Metal
输出轴轴承形式 Bearing at output	滚动轴承Ball bearings
最大允许径向负载(离法兰10mm处) Max. Radial load (10mm from flange)	≤400N
最大允许轴向负载Max. shaft axial load	≤120N
径向间隙 (测量点尽量接近法兰) Radial play of shaft (near to flange)	≤0.08mm
轴向间隙 Axial play of shaft	≤0.4mm
背隙 (无负载时) Backlash at no-load	≤1.5°
输出轴最大承受压入力 Shaft press fit force max	≤300N

行星齿轮箱主要性能参数 Planetary Gearbox Specifications
型号 Gearbox Model: 82PN (斜齿齿轮箱, 大扭矩Helical Gear)

减速比 Reduction ratio	额定允许负载 Rated tolerance torque	瞬间允许负载 Max momentary tolerance torque	效率 Efficiency	L (mm)
1/3.65 1/5.36 1/6.55 1/8.63	20N.m	40 N.m	90%	58.3±0.5
1/13.5 1/18.9 1/24.6 1/28 1/33.9 1/44.7 1/67	60 N.m	120 N.m	81%	80.5±0.5
1/81.1 1/91.3 1/102.9 1/119 1/127.7 1/145.4 1/165.6 1/191.6 1/231.6 1/301.7 1/393	120N.m	240 N.m	73%	103.2±0.5

减速比 Reduction ratio	额定允许负载 Rated tolerance torque	瞬间允许负载 Max momentary tolerance torque	效率 Efficiency	L (mm)	重量 (g) Weight(g)
1/3.6 1/4.25 1/5.33	4 N.m	12 N.m	90%	40.3±0.5	520
1/13 1/15 1/18 1/23 1/28	18 N.m	36 N.m	81%	53.8±0.5	710
1/43 1/52 1/61 1/72 1/96 1/121	36 N.m	72 N.m	73%	67.2±0.5	900
1/154 1/187 1/220 1/260 1/307 1/409 1/514 1/645 1/809	45 N.m	90N.m	66%	80.6±0.5	1100

NMRV030.80BL 系列无刷直流涡轮蜗杆轮减速电机
NMRV030.80BL Brushless Dc Worm Gear Motor

图纸 Drawing

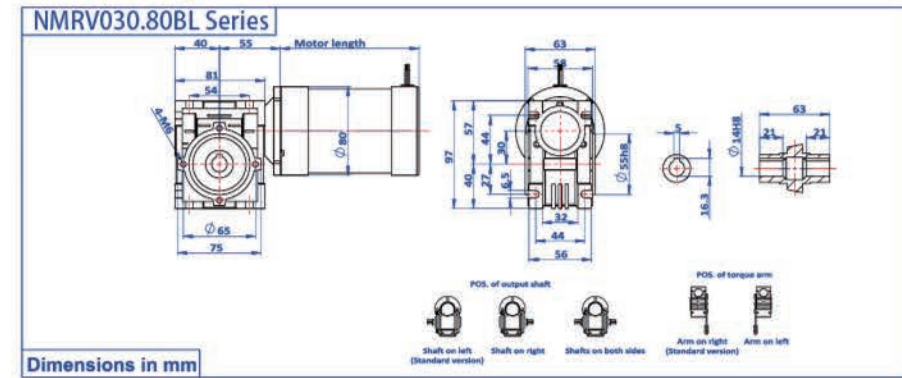

80BL规格参数Technique Specification

型号Model	80RBL01L	80RBL02L	80RBL03L
相数Number of phase	3		
极数 Number of pole	8		
额定电压Voltage	24v(可定制12v 36v 48v); 24v(Option for 12v 36v 48v)		
空载转速No load speed	rpm 2000	rpm 2000	
额定力矩Rated torque	Nm 0.35	Nm 0.6	
额定转速Rated Speed	rpm 1500	rpm 1500	
额定功率Rated Power	W 55	W 94	
机身长度Length	mm 60	mm 80	

NMRV030.80RBL01L 涡轮蜗杆减速电机参数 Worm Gear Motor Specification:

	5	7.5	10	15	20	25	30	40	50	60	80
减速比 Reduction ratio	5	7.5	10	15	20	25	30	40	50	60	80
效率 Transmission Efficiency	90%	85%	85%	80%	75%	75%	70%	65%	60%	55%	50%
空载转速 No Load Speed	Rpm 400	Rpm 267	Rpm 200	Rpm 133	Rpm 100	Rpm 80	Rpm 67	Rpm 50	Rpm 40	Rpm 33	Rpm 25
额定转速 Rated Speed	Rpm 300	Rpm 200	Rpm 150	Rpm 100	Rpm 75	Rpm 60	Rpm 50	Rpm 38	Rpm 30	Rpm 25	Rpm 19
额定力矩 Rated Torque	N.m 1.58	N.m 2.23	N.m 2.98	N.m 4.20	N.m 5.25	N.m 6.56	N.m 7.35	N.m 9.10	N.m 10.50	N.m 11.55	N.m 14.00

NMRV030.80RBL02L 涡轮蜗杆减速电机参数 Worm Gear Motor Specification:

	5	7.5	10	15	20	25	30	40	50	60	80
减速比 Reduction ratio	5	7.5	10	15	20	25	30	40	50	60	80
效率 Transmission Efficiency	90%	85%	85%	80%	75%	75%	70%	65%	60%	55%	50%
空载转速 No Load Speed	Rpm 400	Rpm 267	Rpm 200	Rpm 133	Rpm 100	Rpm 80	Rpm 67	Rpm 50	Rpm 40	Rpm 33	Rpm 25
额定转速 Rated Speed	Rpm 300	Rpm 200	Rpm 150	Rpm 100	Rpm 75	Rpm 60	Rpm 50	Rpm 38	Rpm 30	Rpm 25	Rpm 19
额定力矩 Rated Torque	N.m 2.70	N.m 3.83	N.m 5.10	N.m 7.20	N.m 9.00	N.m 11.25	N.m 12.60	N.m 15.60	N.m 18.00	N.m 19.80	N.m 24.00

NMRV030.80RBL03L 涡轮蜗杆减速电机参数 Worm Gear Motor Specification:

	5	7.5	10	15	20	25	30	40	50	60	80
减速比 Reduction ratio	5	7.5	10	15	20	25	30	40	50	60	80
效率 Transmission Efficiency	90%	85%	85%	80%	75%	75%	70%	65%	60%	55%	50%
空载转速 No Load Speed	Rpm 400	Rpm 267	Rpm 200	Rpm 133	Rpm 100	Rpm 80	Rpm 67	Rpm 50	Rpm 40	Rpm 33	Rpm 25
额定转速 Rated Speed	Rpm 300	Rpm 200	Rpm 150	Rpm 100	Rpm 75	Rpm 60	Rpm 50	Rpm 38	Rpm 30	Rpm 25	Rpm 19
额定力矩 Rated Torque	N.m 4.50	N.m 6.38	N.m 8.50	N.m 12.00	N.m 15.00	N.m 18.75	N.m 21.00	N.m 26.00	N.m 30.00	N.m 33.00	N.m 40.00

NMRV040.80BL 系列无刷直流涡轮蜗杆轮减速电机
NMRV040.80BL Brushless Dc Worm Gear Motor

图纸 Drawing

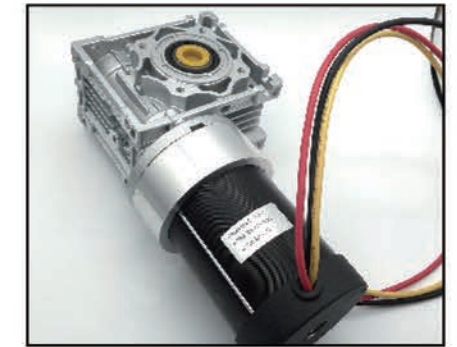
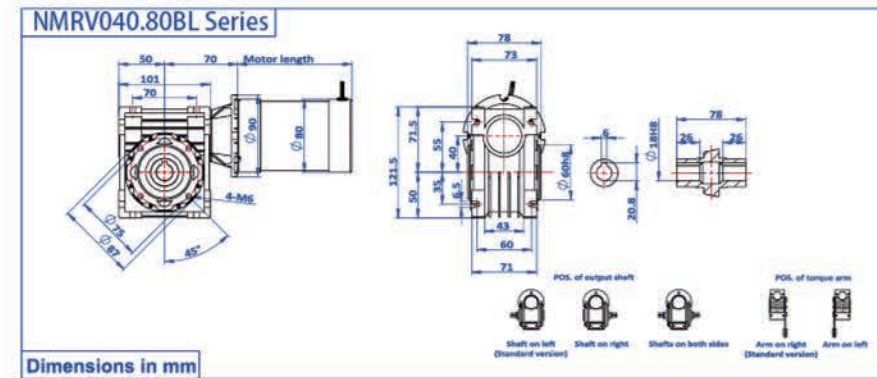

80BL规格参数Technique Specification

型号Model	80RBL01M	80RBL02M	80RBL03M	80RBL04M	80RBL05M
相数Number of phase	3				
极数 Number of pole	8				
额定电压Voltage	24v(可定制12v 36v 48v); 24v(Option for 12v 36v 48v)				
空载转速No load speed	rpm 3100	rpm 3100	rpm 3100	rpm 3100	rpm 3100
额定力矩Rated torque	Nm 0.4	Nm 0.8	Nm 1.2	Nm 1.4	Nm 1.8
额定转速Rated Speed	rpm 2200	rpm 2200	rpm 2200	rpm 2200	rpm 2200
额定功率Rated Power	W 92	W 185	W 277	W 324	W 416
机身长度Length	mm 60	mm 80	mm 100	mm 115	mm 135

NMRV040.80RBL01M 涡轮蜗杆减速电机参数 Worm Gear Motor Specification:

	5	7.5	10	15	20	25	30	40	50	60	80
减速比 Reduction ratio	5	7.5	10	15	20	25	30	40	50	60	80
效率 Transmission Efficiency	90%	85%	85%	80%	75%	75%	70%	65%	60%	55%	50%
空载转速 No Load Speed	Rpm 620	Rpm 413	Rpm 310	Rpm 207	Rpm 155	Rpm 124	Rpm 103	Rpm 78	Rpm 62	Rpm 52	Rpm 39
额定转速 Rated Speed	Rpm 440	Rpm 293	Rpm 220	Rpm 147	Rpm 110	Rpm 88	Rpm 73	Rpm 55	Rpm 44	Rpm 37	Rpm 28
额定力矩 Rated Torque	N.m 1.80	N.m 2.55	N.m 3.40	N.m 4.80	N.m 6.00	N.m 7.50	N.m 8.40	N.m 10.40	N.m 12.00	N.m 13.20	N.m 16.00

NMRV040.80RBL02M 涡轮蜗杆减速电机参数 Worm Gear Motor Specification:

	5	7.5	10	15	20	25	30	40	50	60	80
减速比 Reduction ratio	5	7.5	10	15	20	25	30	40	50	60	80
效率 Transmission Efficiency	90%	85%	85%	80%	75%	75%	70%	65%	60%	55%	50%
空载转速 No Load Speed	Rpm 620	Rpm 413	Rpm 310	Rpm 207	Rpm 155	Rpm 124	Rpm 103	Rpm 78	Rpm 62	Rpm 52	Rpm 39
额定转速 Rated Speed	Rpm 440	Rpm 293	Rpm 220	Rpm 147	Rpm 110	Rpm 88	Rpm 73	Rpm 55	Rpm 44	Rpm 37	Rpm 28
额定力矩 Rated Torque	N.m 3.60	N.m 5.10	N.m 6.80	N.m 9.60	N.m 12.00	N.m 15.00	N.m 16.80	N.m 20.80	N.m 24.00	N.m 26.40	N.m 32.00

NMRV040.80RBL03M 涡轮蜗杆减速电机参数 Worm Gear Motor Specification:

	5	7.5	10	15	20	25	30	40	50	60	80
减速比 Reduction ratio	5	7.5	10	15	20	25	30	40	50	60	80
效率 Transmission Efficiency	90%	85%	85%	80%	75%	75%	70%	65%	60%	55%	50%
空载转速 No Load Speed	Rpm 620	Rpm 413	Rpm 310	Rpm 207	Rpm 155	Rpm 124	Rpm 103	Rpm 78	Rpm 62	Rpm 52	Rpm 39
额定转速 Rated Speed	Rpm 440	Rpm 293	Rpm 220	Rpm 147	Rpm 110	Rpm 88	Rpm 73	Rpm 55	Rpm 44	Rpm 37	Rpm 28
额定力矩 Rated Torque	N.m 5.40	N.m 7.65	N.m 10.20	N.m 14.40	N.m 18.00	N.m 22.50	N.m 25.20	N.m 31.20	N.m 36.00	N.m 39.60	N.m 48.00

NMRV040.80RBL04M 涡轮蜗杆减速电机参数 Worm Gear Motor Specification:

	5	7.5	10	15	20	25	30	40	50	60	80
减速比 Reduction ratio	5	7.5	10	15	20	25	30	40	50	60	80
效率 Transmission Efficiency	90%	85%	85%	80%	75%	75%	70%	65%	60%	55%	50%
空载转速 No Load Speed	Rpm 620	Rpm 413	Rpm 310	Rpm 207	Rpm 155	Rpm 124	Rpm 103	Rpm 78	Rpm 62	Rpm 52	Rpm 39
额定转速 Rated Speed	Rpm 440	Rpm 293	Rpm 220	Rpm 147	Rpm 110	Rpm 88	Rpm 73	Rpm 55	Rpm 44	Rpm 37	Rpm 28
额定力矩 Rated Torque	N.m 6.30	N.m 8.93	N.m 11.90	N.m 16.80	N.m 21.00	N.m 26.25	N.m 29.40	N.m 36.40	N.m 42.00	N.m 46.20	N.m 56.00

NMRV040.80RBL05M 涡轮蜗杆减速电机参数 Worm Gear Motor Specification:

	5	7.5	10	15	20	25	30	40	50	60	80
减速比 Reduction ratio	5	7.5	10	15	20	25	30	40	50	60	80
效率 Transmission Efficiency	90%	85%	85%	80%	75%	75%	70%	65%	60%	55%	50%
空载转速 No Load Speed	Rpm 620	Rpm 413	Rpm 310	Rpm 207	Rpm 155	Rpm 124	Rpm 103	Rpm 78	Rpm 62	Rpm 52	Rpm 39
额定转速 Rated Speed	Rpm 440	Rpm 293	Rpm 220	Rpm 147	Rpm 110	Rpm 88	Rpm 73	Rpm 55	Rpm 44	Rpm 37	Rpm 28
额定力矩 Rated Torque	N.m 8.10	N.m 11.48	N.m 15.30	N.m 21.60	N.m 27.00	N.m 33.75	N.m 37.80	N.m 46.80	N.m 54.00	N.m 59.40	N.m 70.00

NMRV050.80BL 系列无刷直流涡轮蜗杆轮减速电机
NMRV050.80BL Brushless Dc Worm Gear Motor

图纸 Drawing

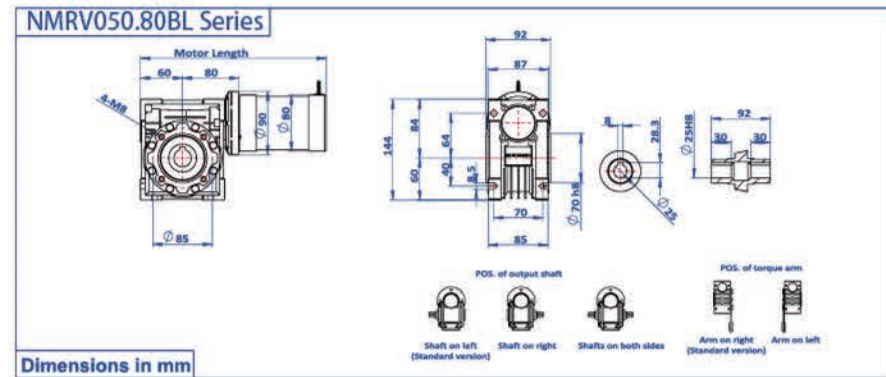

80BL规格参数Technique Specification

型号Model	80RBL01M	80RBL02M	80RBL03M	80RBL04M	80RBL05M	
相数 Number of phase	3					
极数 Number of pole	8					
额定电压 Voltage	24v(可定制 12v 36v 48v); 24v(Option for 12v 36v 48v)					
空载转速 No load speed	rpm	3100	3100	3100	3100	3100
额定力矩 Rated torque	Nm	0.4	0.8	1.2	1.4	1.8
额定转速 Rated Speed	rpm	2200	2200	2200	2200	2200
额定功率 Rated Power	W	92	185	277	324	
机身长度 Length	mm	60	80	100	115	135

NMRV050.80RBL01M 涡轮蜗杆减速电机参数 Worm Gear Motor Specification:

参数	5	7.5	10	15	20	25	30	40	50	60	80	100
减速比 Reduction ratio	5	7.5	10	15	20	25	30	40	50	60	80	100
效率 Transmission Efficiency	90%	85%	85%	80%	75%	75%	70%	65%	60%	55%	50%	45%
空载转速 No Load Speed	Rpm	620	413	310	207	155	124	103	78	62	52	39
额定转速 Rated Speed	Rpm	440	293	220	147	110	88	73	55	44	37	28
额定力矩 Rated Torque	N.m	1.80	2.55	3.40	4.80	6.00	7.50	8.40	10.40	12.00	13.20	16.00

NMRV050.80RBL02M 涡轮蜗杆减速电机参数 Worm Gear Motor Specification:

参数	5	7.5	10	15	20	25	30	40	50	60	80	100
减速比 Reduction ratio	5	7.5	10	15	20	25	30	40	50	60	80	100
效率 Transmission Efficiency	90%	85%	85%	80%	75%	75%	70%	65%	60%	55%	50%	45%
空载转速 No Load Speed	Rpm	620	413	310	207	155	124	103	78	62	52	39
额定转速 Rated Speed	Rpm	440	293	220	147	110	88	73	55	44	37	28
额定力矩 Rated Torque	N.m	3.60	5.10	6.80	9.60	12.00	15.00	16.80	20.80	24.00	26.40	32.00

NMRV050.80RBL03M 涡轮蜗杆减速电机参数 Worm Gear Motor Specification:

参数	5	7.5	10	15	20	25	30	40	50	60	80	100
减速比 Reduction ratio	5	7.5	10	15	20	25	30	40	50	60	80	100
效率 Transmission Efficiency	90%	85%	85%	80%	75%	75%	70%	65%	60%	55%	50%	45%
空载转速 No Load Speed	Rpm	620	413	310	207	155	124	103	78	62	52	39
额定转速 Rated Speed	Rpm	440	293	220	147	110	88	73	55	44	37	28
额定力矩 Rated Torque	N.m	5.40	7.65	10.20	14.40	18.00	22.50	25.20	31.20	36.00	39.60	48.00

NMRV050.80RBL04M 涡轮蜗杆减速电机参数 Worm Gear Motor Specification:

参数	5	7.5	10	15	20	25	30	40	50	60	80	100
减速比 Reduction ratio	5	7.5	10	15	20	25	30	40	50	60	80	100
效率 Transmission Efficiency	90%	85%	85%	80%	75%	75%	70%	65%	60%	55%	50%	45%
空载转速 No Load Speed	Rpm	620	413	310	207	155	124	103	78	62	52	39
额定转速 Rated Speed	Rpm	440	293	220	147	110	88	73	55	44	37	28
额定力矩 Rated Torque	N.m	6.30	8.93	11.90	16.80	21.00	26.25	29.40	36.40	42.00	46.20	56.00

NMRV050.80RBL05M 涡轮蜗杆减速电机参数 Worm Gear Motor Specification:

参数	5	7.5	10	15	20	25	30	40	50	60	80	100
减速比 Reduction ratio	5	7.5	10	15	20	25	30	40	50	60	80	100
效率 Transmission Efficiency	90%	85%	85%	80%	75%	75%	70%	65%	60%	55%	50%	45%
空载转速 No Load Speed	Rpm	620	413	310	207	155	124	103	78	62	52	39
额定转速 Rated Speed	Rpm	440	293	220	147	110	88	73	55	44	37	28
额定力矩 Rated Torque	N.m	8.10	11.48	15.30	21.60	27.00	33.75	37.80	46.80	54.00	59.40	70.00

NMRV040.86BL 系列无刷直流涡轮蜗杆轮减速电机
NMRV040.86BL Brushless Dc Worm Gear Motor

图纸 Drawing

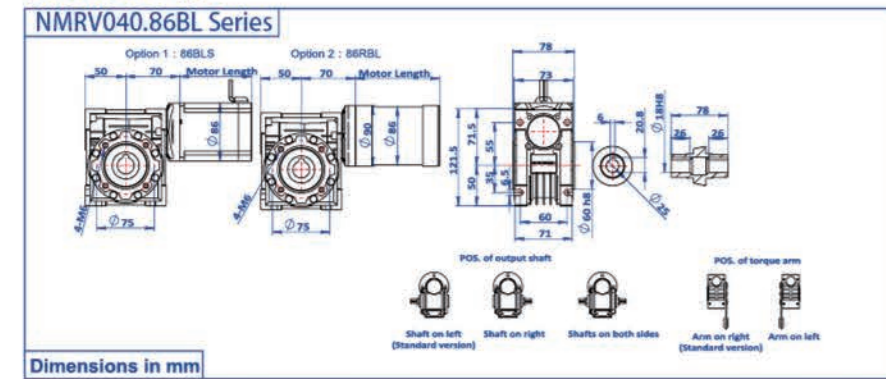

86BL电机规格参数Motor Technique Specification

型号Model	86RBL01L/86BLS01L	86RBL02L/86BLS02L	86RBL03L/86BLS03L	
相数 Number of phase	3			
极数 Number of pole	8			
额定电压 Voltage	48v(可定制 12v 24v 36v); 48v(Option for 12v 24v 36v)			
空载转速 No load speed	rpm	2000	2000	2000
额定力矩 Rated torque	Nm	0.75	1.5	2.0
额定转速 Rated Speed	rpm	1500	1500	1500
额定功率 Rated Power	W	118	236	315
机身长度 Length	mm	80	105	130

NMRV040.86BL01L/86BLS01L 涡轮蜗杆减速电机参数 Worm Gear Motor Specification:

参数	5	7.5	10	15	20	25	30	40	50	60	80	100
减速比 Reduction ratio	5	7.5	10	15	20	25	30	40	50	60	80	100
效率 Transmission Efficiency	90%	85%	85%	80%	75%	75%	70%	65%	60%	55%	50%	45%
空载转速 No Load Speed	Rpm	400	267	200	133	100	80	67	50	40	33	25
额定转速 Rated Speed	Rpm	300	200	150	100	75	60	50	38	30	25	19
额定力矩 Rated Torque	N.m	3.38	4.78	6.38	9.00	11.25	14.06	15.75	19.50	22.50	24.75	30.00

NMRV040.86BL02L/86BLS02L 涡轮蜗杆减速电机参数 Worm Gear Motor Specification:

参数	5	7.5	10	15	20	25	30	40	50	60	80	100
减速比 Reduction ratio	5	7.5	10	15	20	25	30	40	50	60	80	100
效率 Transmission Efficiency	90%	85%	85%	80%	75%	75%	70%	65%	60%	55%	50%	45%
空载转速 No Load Speed	Rpm	400	267	200	133	100	80	67	50	40	33	25
额定转速 Rated Speed	Rpm	300	200	150	100	75	60	50	38	30	25	19
额定力矩 Rated Torque	N.m	6.75	9.56	12.75	18.00	22.50	28.13	31.50	39.00	45.00	49.50	60.00

NMRV040.86BL03L/86BLS03L 涡轮蜗杆减速电机参数 Worm Gear Motor Specification:

参数	5	7.5	10	15	20	25	30	40	50	60	80	100
减速比 Reduction ratio	5	7.5	10	15	20	25	30	40	50	60	80	100
效率 Transmission Efficiency	90%	85%	85%	80%	75%	75%	70%	65%	60%	55%	50%	45%
空载转速 No Load Speed	Rpm	400	267	200	133	100	80	67	50	40	33	25
额定转速 Rated Speed	Rpm	300	200	150	100	75	60	50	38	30	25	19
额定力矩 Rated Torque	N.m	9.00	12.75	17.00	24.00	30.00	37.50	42.00	52.00	60.00	66.00	70.00



NMRV050.86BL 系列无刷直流涡轮蜗杆轮减速电机
NMRV050.86BL Brushless Dc Worm Gear Motor

图纸 Drawing

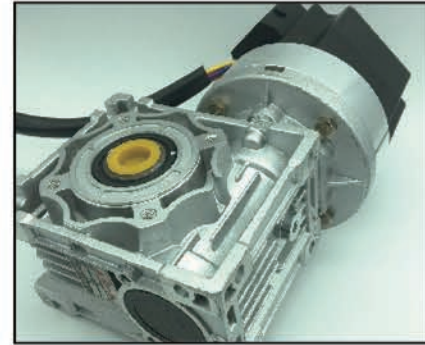
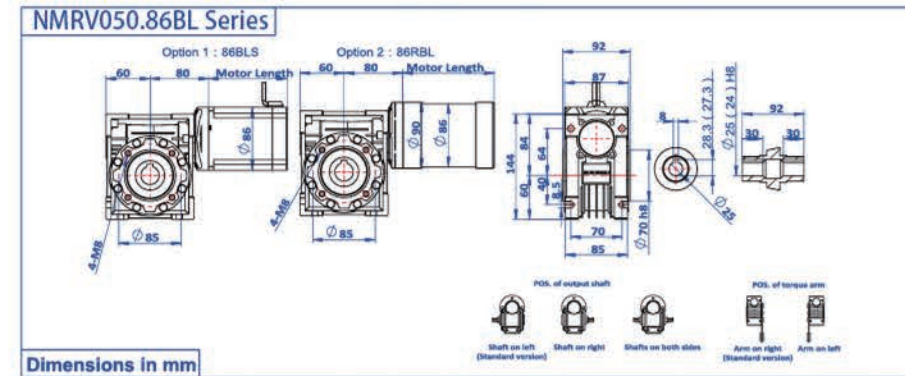

86BL电机规格参数Motor Technique Specification

型号Model	86RBL01M/86BLS01M	86RBL02M/86BLS02M	86RBL03M/86BLS03M
相数Number of phase	3		
极数 Number of pole	8		
额定电压Voltage	48v(可定制12v 24v 36v);48v(Option for 12v 24v 36v)		
空载转速No load speed	rpm	3000	3000
额定力矩Rated torque	Nm	1.0	1.8
额定转速Rated Speed	rpm	2200	2200
额定功率Rated Power	W	230	415
机身长度Length	mm	80	105

NMRV050. 86BL01M/86BLS01M涡轮蜗杆减速电机参数 Worm Gear Motor Specification:

减速比 Reduction ratio	5	7.5	10	15	20	25	30	40	50	60	80	100
效率 Transmission Efficiency	90%	85%	85%	80%	75%	75%	70%	65%	60%	55%	50%	45%
空载转速 No Load Speed	Rpm	600	400	300	200	150	120	100	75	60	50	38
额定转速 Rated Speed	Rpm	440	293	220	147	110	88	73	55	44	37	28
额定力矩 Rated Torque	N.m	4.50	6.38	8.50	12.00	15.00	18.75	21.00	26.00	30.00	33.00	40.00

NMRV050. 86BL02M/86BLS02M 涡轮蜗杆减速电机参数 Worm Gear Motor Specification:

减速比 Reduction ratio	5	7.5	10	15	20	25	30	40	50	60	80	100
效率 Transmission Efficiency	90%	85%	85%	80%	75%	75%	70%	65%	60%	55%	50%	45%
空载转速 No Load Speed	Rpm	600	400	300	200	150	120	100	75	60	50	38
额定转速 Rated Speed	Rpm	440	293	220	147	110	88	73	55	44	37	28
额定力矩 Rated Torque	N.m	8.10	11.48	15.30	21.60	27.00	33.75	37.80	46.80	54.00	59.40	72.00

NMRV050. 86BL03M/86BLS03M 涡轮蜗杆减速电机参数 Worm Gear Motor Specification:

减速比 Reduction ratio	5	7.5	10	15	20	25	30	40	50	60	80	100
效率 Transmission Efficiency	90%	85%	85%	80%	75%	75%	70%	65%	60%	55%	50%	45%
空载转速 No Load Speed	Rpm	600	400	300	200	150	120	100	75	60	50	38
额定转速 Rated Speed	Rpm	440	293	220	147	110	88	73	55	44	37	28
额定力矩 Rated Torque	N.m	11.25	15.94	21.25	30.00	37.50	46.88	52.50	65.00	75.00	82.50	90.0

可按客户要求定制:

- 1.电压 电性能
- 2.法兰 端盖 出轴 引出线 接插件
- 3.EMC电路
- 4.过压保护 过热保护
- 5.高温等级 防水要求
- 6.减速器 控制器 编码器 刹车等一体化

Customized Specifications

- 1.Customized voltage,motor performance
- 2.Customized mounting,shaft,and lead configuration
- 3.EMI/RFI suppression circuit
- 4.Overload protection,Thermal protection
- 5.High temperature and water-proof option
- 6.Integrated gearbox,controller,encoder and brake

CUSTOM & OEM



Automobile door motor



Automobile fuel pump motor



Big power lifting motor



Bldc robot motor



Brushless dc fan motor



Brushless Spindle Motor



Bus door open bldc gearmotor



CNC dc motor



Gearmotor brake encoder integrated



Golf trolley motor



Hollow shaft bldc motor



Hydraulic pump dc motor



Medical pump dc motor



motor with magnet encoder



Special worm shaft motor



Wheelchair dc motor